



LINDSTRAND TECHNOLOGIES LTD

UNDERGROUND WINCH SYSTEM OPERATIONS & MAINTENANCE MANUAL

Winch Serial No.: LTL

Lindstrand Technologies Ltd
Maesbury Road
Oswestry
Shropshire
SY10 8HA
UK

Tel: +44 (0)1691 671 888

Fax: +44 (0)1691 679 991

www.lindstrandtech.com

All rights reserved. No part of this manual may be reproduced or transmitted in any form or by any means, electronic, or mechanical, including photocopy, recording, or any information storage and retrieval system, without permission in writing from Lindstrand Technologies Ltd, Maesbury Road, Oswestry, Shropshire, SY10 8HA, England

1	Winch System Overview	1
1.1	Identification	1
1.2	Winch Description	1
1.3	Winch Features	2
2	Winch System Components	3
2.1	Winch Cable	3
2.2	Gimbal Sheave	3
2.3	Fleeting Sheave	3
2.4	Winch Drum	4
2.5	Main Drive Motor/Gearbox Unit	4
2.6	Hydraulic Disc Brake	4
2.7	Auxiliary Motor/Gear Drive	5
2.8	Auxiliary Generator	5
2.9	Bilge Pump	6
2.10	Fire Extinguisher	6
3	Monitoring System	7
3.1	Monitors	7
3.1.1	Encoder	7
3.1.2	Proximity Counter	7
3.1.3	Rope Overtravel Switch	7
3.1.4	Fleeting sheave pay-out & pay-in switches	7
3.1.5	Landing Proximity Sensor	8
3.1.6	Cable Disc Overtravel Switches	8
4	Control System	9
4.1	The Control Cabinet	9
4.2	Resistor Bank	9
4.3	Mains Power Switch	9
4.4	Visual Display Screen	9
4.5	Visual Display Screen Functions	10
4.6	Screen Operation	10
Figure A	Main Screen	12
Figure B	Alarms	13
Figure C	Rides Screen	14
Figure D	Ride Height Screen	15
Figure E	Engineering Screen	16
Figure F	Encoder Screen	17
Figure G	Winch Brake Control Screen	18
5	Operation Controls	19
5.1	Gondola Control	19
5.2	Ground Control	19
6	Winch System Failures	21
6.1	Gondola Control Failure	21
6.2	Mains Power Supply Failure	21
6.3	Auxiliary Pinion Cover Override	22

6.4	'E-stop' locked by cable disc	22
6.5	Mains and generator power failure	23
6.6	Main Motor Brake Locks 'on'	24
6.7	Hydraulic disc brake locks 'ON'	25
6.8	Winch Control Inoperative	26
6.9	Main Motor disabled	27
6.10	Ride Height Zero	28
6.11	High Wind Recovery	28
7	Balloon Mooring System	29
7.1	Mooring Winch Location	29
7.2	Mooring Winches	29
7.3	Mooring Winch control	29
7.4	Pendant Control Unit	29
7.4.1	'E-stop' and Reset Button	30
7.4.2	Raise/lower switch	30
7.4.3	Moor Outer – controls	30
7.4.4	Moor Inner – controls	30
7.4.5	Overload tripped warning	30
8	Electrical Systems	31
8.1	Air Conditioning Systems	31
8.2	110v Transformer (TX2)	31
8.3	K30 and K31	31
8.4	110v Transformer (TX3)	31
8.5	Brake Hydraulic Motor	31
8.6	Auxiliary Motor	32
8.7	Brake Unit	32
8.8	Winch Blower Motor	32
8.9	24v DC Power Supply	32
8.10	24v DC Health K44	32
8.11	Drum Speed Monitor	32
8.12	Pay-out Proximity Sensor	33
8.13	Balloon Parked Photo Eye	33
8.14	Emergency Stop Circuit 'E-stop'	33
8.14.1	'E-stop' Loop	33
8.14.2	Relay Check Circuit	34
8.14.3	Reset Relay	34
8.15	Mains 'On' light	35
8.16	Reset push buttons	35
8.17	Lamp test buttons	35
8.18	Winch Drive enable	35
8.19	Winch Blower	35
8.20	Brake Solenoid 1 & 2 (K42)	35
8.21	Auxiliary Motor Activation	36
8.22	Auxiliary Motor Run	36
8.23	Normal/Recovery Keyswitch	36
8.24	Hydraulic Brake activation	36
8.25	Pressure Switch (PS1)	36
8.26	Coupling Engaged Proximity Sensor	36

8.27	Coupling Engaged Lamp	36
8.28	Invertor	37
8.28.1	Power Supply	37
8.28.2	Digital Inputs	37
8.28.3	Relay Outputs	37
8.28.4	Resistor Bank	37
8.28.5	Thermistor Relay	38
8.29	PLC (Programmable Logic Control)	38
9	Electrical Fault Finding	39
9.1	Main Safety Relay Trip	39
9.2	Generator CB Trip Q30	39
9.3	Mains supply CB Trip Q31	39
9.4	Brake Hydraulic Trip Q33	39
9.5	Auxiliary Motor CB Trip Q32	39
9.6	MD Brake Unit CB Trip Q34	40
9.7	Winch Blower CB Trip Q35	40
9.8	Winch Drive Fault	40
9.9	Pilz Overspeed Trip	40
9.10	Resistor Overheat	40
9.11	Main Panel 'E-stop'	41
9.12	Remote Station 'E-stop'	41
9.13	Main winch 'E-stop'	41
9.14	Disc Overtravel (1 or 2)	41
9.15	Rope Overtravel	41
9.16	Fleeting Sheave In	41
9.17	Fleeting Sheave pay-out switch tripped	42
9.18	Height Count Error	42
9.19	Low Oil Level	42
9.20	Coupling Guard Open	42
9.21	Thermistor Trip	42
10	Inspection & Maintenance	43
10.1	General Care	43
10.2	Preventative Maintenance	43
10.3	Daily Inspection	44
10.4	Weekly Maintenance	44
10.5	Annual Survey	44
10.5.1	3-yearly Service	44
10.5.2	5-yearly Service	44
10.6	Defects	44
10.7	Daily Inspection Schedule	45
10.7.1	Tether Cable	45
10.7.2	Cable Termination	45
10.7.3	Winch Structures	45
10.7.4	Hydraulic brake system	45
10.7.5	Disengage brake systems/Static Dynamic testing	46
10.7.6	Fleeting Sheave	46
10.7.7	Gimbal Sheave	46
10.7.8	Auxiliary Generator	46

10.7.9	Winch Housing	47
10.7.10	Electrical System	47
10.8	Weekly Maintenance Schedule	47
10.8.1	Gearbox Oil	47
10.8.2	Gimbal Sheave	47
10.8.3	Fleeting Sheave	48
10.8.4	Auxiliary Gear Drive	48
10.8.5	Cable Swivel	48
10.8.6	Bilge Pump	48
10.8.7	Emergency Recovery Procedures	48
11	Winch Lubrication	49
11.1	Winch Gearboxes	49
11.2	Mooring winch gearboxes	49
11.3	Oil Specification	49
11.4	Greasing Points	50
11.4.1	Gimbal Sheave	50
11.4.2	Fleeting Sheave	50
11.4.3	Drum shaft bearings	50
11.4.4	Final Drive gearbox	50
11.4.5	Auxiliary motor gear drive	50
11.4.6	Brake Hydraulic Power Unit	51
11.4.7	Cable Swivel	51
Figure		
1	Winch System Layout	52
2	Cable termination	53
3	Disc Brake Power Unit	54
4	Auxiliary Drive Pinion Engagement	55
5	Fleeter Limit Stops	56
6	Control Cabinet	57
7	Winch Control Panel	58
8	Ground Control Panel	59
9	Mooring Pendant Control	60
Appendix 1	Daily Lindstrand Winch Inspection Report Form	61 – 62
Appendix 2	Lindstrand Winch System – Weekly Maintenance Form	63
Appendix 3	Lindstrand Winch Annual Inspection Form	64 – 65
Appendix 4	Lindstrand Winch 3-Yearly Inspection Form	66
Appendix 5	Lindstrand Winch 5-Yearly Inspection Form	67
Appendix 6	Defect Report Form	68
Appendix 7	Lindstrand Winch Emergency Recovery Procedures	
	Display Sheet 1	69
	Display Sheet 2	70

1 WINCH SYSTEM OVERVIEW

1.1 Identification

The winch is manufactured by:

Lindstrand Technologies Ltd
Maesbury Road
Oswestry
Shropshire
SY10 8HA
UK

Tel: +44 (0) 1691 671 888

Fax: +44 (0) 1691 679 991

www.lindstrandtech.com

The identification plate with the Winch Assembly No WI-002-A-001, and Production Serial No 101 onwards, is attached to the top face of the main frame centre crossmember [see Fig. 1].

1.2 Winch Description

The winch has been designed specifically for use with the Lindstrand HiFlyer passenger-carrying balloon.

The winch's function is to elevate the balloon on the end of a winch cable up to a maximum height of 160 metres, and to winch it back down.

The drum stores 180 metres of cable in a single wrap layer, with a minimum of 4 wraps remaining on the drum at maximum pay-out.

The drum is mounted across the frame on two bearing supports.

The cable is reeled off the main drum passing over a fleeting sheave at the far end of the winch frame and returning to the gimbal sheave at the centre of the winch. The cable exits at the top of the gimbal to attach to the balloon rigging. The fleeting sheave traverses the frame to reduce the angle at which the cable leaves the drum grooves. The gimbal sheave swivels to allow the cable to follow the drift of the balloon in the wind.

The winch is driven by an electric motor through two reduction gear stages. The drum is stopped by the motor and the balloon held by two fail-safe brake systems. A motor brake is fitted to the drive motor and a hydraulic brake acts directly on the drum disc flange. Either brake is capable of holding the balloon independently.

An auxiliary motor with direct gear drive onto the drum gear flange can recover the balloon in case of mains power or mains motor failure.

A back-up generator is linked into the system to drive the auxiliary motor in case of mains power failure.

The winch is controlled from a control cabinet with a complex electrical control system with multiple function inputs and monitored safety stops.

On ascent the balloon is restrained by full dynamic braking on the main motor with electrical energy dissipated into a separate resistor bank. Descent is controlled under direct motor power. The ascent and descent are cushioned by variable electronically controlled soft start and ramp down.

1.3 Winch Features

- Safe working load - 7 tonnes
- Proof-tested to 8 tonnes
- Wire rope cable proof tested to 16.9 tonnes
- Wire rope minimum breaking load - 45 tonnes
- Maximum cable speed – 35m/min
- Rope capacity on drum – 180 metres
- Maximum rope pay-out – 160 metres
- Normal ride height – 120 metres
- Fail-safe motor brake
- Fail-safe hydraulic disc brake on drum flange
- Multiple stop sensors to detect abnormalities
- Operation control from ground or gondola
- Full dynamic braking on main motor
- Electric energy dissipation into resistor bank
- Computer control with visual display
- Auxiliary drive motor
- Back up generator power source
- 20 mooring winches

2 WINCH SYSTEM COMPONENTS

The winch system consists of the following sub-components [see Fig. 1]:

- Winch cable
- Gimbal sheave
- Fleeting sheave
- Main drum
- Main drive braked motor and gearbox
- Hydraulic disc brake
- Auxiliary motor and gear drive
- Backup Generator
- Control cabinet and system
- Balloon mooring system

2.1 Winch Cable

The winch cable is 22mm diameter 'Dyform' 34 x 7 construction, low rotation, steel wire rope, with a minimum breaking load of 45 tonnes. The cable is wrapped around the drum with the fixed end secured to the drum flange with cable clamps.

The balloon end of the cable is terminated with an open spelter socket which is attached to a swivel and load cell [see Fig. 2].

The load cell bow shackle is connected to the two master links of the balloon and gondola rigging system.

A 300mm diameter disc is attached around the cable and positioned 700mm down from the neck of the spelter socket termination.

When the disc descends to 300mm above the sensor mounted on top of the gimbal sheave a 'stop' is activated stopping the motor and descent.

2.2 Gimbal Sheave

The gimbal sheave is mounted with the cable outlet located at the centre of the site, and directly below the centre of the balloon. The sheave is mounted on top of the winch frame.

The gimbal pulley guides the cable from the static winch to the mobile balloon. The gimbal shaft and housing are free to rotate in both planes allowing the sheave 360° of movement to follow the drift of the balloon with the wind. The weight of the sheave is counterbalanced by an underslung weight [see Fig. 1].

2.3 Fleeting Sheave

The fleeting sheave is located at the opposite end of the winch frame. The fleeting sheave is mounted on a threaded shaft and traverses across the frame as the cable travels in or out over the sheave.

The fleeting traverse is approximately half that of the cable on the drum. This reduces the angle of the cable to the drum grooves and enables a wider drum with a single layer of cable wrap to be used, maintaining constant speed and reducing cable wear [see Fig. 1].

2.4 Winch Drum

The winch drum is approximately 1.5 metres diameter with a cable wrap length of 4.8 metres for each revolution. The barrel of the drum is grooved to accept the full 180m length of rope in one layer, ensuring constant torque, speed and minimum wear. One drum flange is used as a brake disc for the caliper brake, the other flange is used as a ring gear for the auxiliary drive. Normal drum speed is 7.0 r.p.m., equivalent to 33.6 metres/minute of cable travel.

The drum shaft is fitted with an encoder to measure drum speed. A proximity counter operating on the drum flange also monitors the drum speed. If either system detects an overspeed an emergency 'E-stop' will be activated.

In this case, the system must be reset and the balloon recovered with the Emergency keyswitch or Auxiliary motor [see Sections 6.8 and 6.9].

2.5 Main Drive Motor/Gearbox unit

The main drive motor, brake, and gearbox are assembled as an integrated unit driving directly onto the drum shaft at 90°. The motor is a 37 kW, 3-phase unit, powered through a drive system that controls speed and ride height.

Normal motor speed is 1470 r.p.m. reduced through two gearbox stages to an output speed of 7.0 r.p.m. to the drum.

The motor is fitted with a spring operated fail-safe brake which is automatically engaged at the end of the ascent or descent cycle, or in case of power failure, or an emergency stop.

2.6 Hydraulic Disc Brake

The fail-safe hydraulic brake acts directly on the drum flange.

The brake caliper applies brake pads onto the flange disc to stop the drum rotating.

The brake is automatically applied by a mechanical spring force.

Hydraulic pressure from an electrically driven power pack is used to overcome the spring pressure and release the brake. The pressure range displayed on the gauge should be from 100 bar rising to 80 bar falling [see Fig. 3].

The hydraulic power pack is controlled by electric solenoid valves activated by the winch control system to apply and release the brakes at the start and finish of the balloon ride. The brake will also be applied by the 'stop' and 'emergency stop' commands.

The hydraulic fluid level must be checked regularly [see Section 11.4.6].

A failure in the electricity supply or hydraulic power pack will cause the brake to apply. The brake can be released with the manual pump located adjacent to the brake mechanism.

WARNING – The manual release must only be used in emergency procedure [see Section 6.7].

2.7 Auxiliary Motor/Gear Drive

The auxiliary drive geared motor is located behind the drum at the opposite end of the frame from the fleeting sheave.

The motor is a 7.5kW 3 phase unit with a normal motor speed of 1430 r.p.m. and an output speed of 20 r.p.m. at the gearbox drive shaft. A pinion gear wheel is mounted on the drive shaft.

In an emergency resulting from the failure of the mains motor or power supply, the balloon can be recovered with the auxiliary motor under mains or generator power.

Before operating the auxiliary drive, the 18-tooth auxiliary motor pinion gear must be manually engaged to mesh with the 178-tooth ring gear on the drum flange [see Fig. 4].

With the pinion drive turning at 20 r.p.m. the drum will rotate at approximately 2 r.p.m. giving a recovery descent speed of 9.6 metres/.min: equating to 12.5 min from 120m ride height.

The auxiliary drive controls are located on the main control panel on the control cabinet in the winch pit. The operating procedure is detailed in **Section 6.2**.

2.8 Auxiliary Generator

The auxiliary generator is normally located in the winch housing, but can also be located elsewhere on the site if required.

If fitted in a housing the exhaust gas must be vented outside to atmosphere.

In case of mains power failure the generator is vital to the recovery of the balloon. The generator set must be correctly maintained and regularly serviced. An automated battery charger must be permanently on site and the battery state monitored.

A fire extinguisher must be accessible.

A full container of fuel must be on site at all times, and stored outside winch housing.

The generator set consists of a water-cooled diesel engine in the 20kW (26HP) range driving a 20KVA, 3 phase 415 V generator producing 28 amps. The generator set will include a fuel tank, control/instrument panel with starter switch and a circuit breaker.

Daily servicing will include checking fuel, coolant, and oil levels, and battery charge state. The engine should be started daily and run for at least ten minutes to warm up before switching off.

The generator set manufacturer's Installation, Operation and Instruction Manual must be consulted and complied with before installing and operating the generator.

The contact numbers for the following services should be displayed near the generator:

- Mains electricity supply company
- Generator service engineer
- Mobile generator agent.

2.9 Bilge Pump

This must be supplied locally – it is not supplied by Lindstrand Technologies Ltd.

A bilge pump is required to remove any water than collects in the winch housing.

The pump is located in the well in the lowest corner of the housing. The pump should be powered from the mains electrical supply, automatically activated by a float switch.

The minimum flow rate is 45 litres/min (10 gallons/min).

An outlet pipe will be required to discharge the water to a drainage point.

2.10 Fire Extinguisher

This must be supplied locally – it is not supplied by Lindstrand Technologies Ltd.

A standard Carbon Dioxide (CO₂) extinguisher must be installed in an accessible position in the winch housing.

The extinguisher must meet local fire regulation requirements.

3 MONITORING SYSTEM

This system monitors the status and controls the operation of the winch and balloon.

3.1 Monitors

Monitoring devices and safety stops are located around the winch to indicate speed and position, and trigger stops and alarms if safe limits are exceeded.

Faults will be indicated and identified on the Visual Display Screen.

3.1.1 Encoder

An encoder is mounted on the end of the drum shaft. The encoder registers speed and balloon ride height.

The balloon height is displayed on the data monitor screen.

The encoder will activate an 'alarm' and 'E-stop' if an 'overspeed' is detected.

3.1.2 Proximity Counter

The 'proxy' counter is mounted on the gimbal frame opposite to the motor side.

The counter reads the drum speed from detectors in the drum flange and displays ride height on the data screen. The counter acts as a backup to the encoder.

3.1.3 Rope overtravel switch

The limit switch is mounted on the frame between the drum and fleeting sheave.

If too much cable is wound off the drum the cable will trigger the switch activating an alarm and 'E-stop'.

To reset the system the switch must be loosened and physically slid away from the rope. The system can then be reset, and the balloon descended. The fault must be rectified and the switch returned to its correct position before operations are continued.

3.1.4 Fleeting Sheave pay-out and pay-in switches

The limit switches are mounted on the frame either side of the fleeter pulley wheel. If too much rope is payed out or the pulley wheel is out of adjustment the side of the pulley will trigger a switch activating an alarm and 'E-stop'.

To reset the system the switch must be loosened and physically slid away from the pulley. The system can then be reset and the balloon descended.

The pulley position on the shaft must be adjusted and the switch returned to its correct position before operations are continued.

See Fig. 5 for settings of fleeter pulley and limit switches.

3.1.5 Landing Proximity Sensor

An ultrasonic proximity sensor (photo eye) is mounted on the top face of the gimbal sheave. The switch detects the proximity of the cable disc as the balloon approaches and stops the descent when the gondola has landed.

The final landing onto the platform is conducted manually from the 'ground control'.

3.1.6 Cable Disc Overtravel Switches

Two disc overtravel switches are mounted on top of the gimbal cover. If the 'proximity sensor' fails to stop the descent the cable disc will activate the switches and trigger an alarm and 'E-stop'.

The disc position must be marked with tape and the disc loosened and slid up the cable before the system can be reset.

Ascend the cable 1 metre, return the disc to its correct position and clamp.

4 CONTROL SYSTEM

The control system sets and controls the operational status of the winch.

4.1 The Control Cabinet

The cabinet is located in the winch housing, and is the focal point of the control system.

It houses the electrical and electronic systems including the Visual Display Screen, Programmable Logic Controller (P.L.C.), inverters, circuit breakers and contactors.

The mains power switch, mooring winch power switch, visual display screen, winch control panel, and emergency recovery controls are mounted in the front doors of the cabinet **[see Fig. 6]**.

4.2 Resistor Bank

The resistor bank is mounted on the top of the cabinet. The internal resistor elements disperse the electrical energy generated by the dynamic braking of the main motor restraining the balloon lift as it ascends.

The energy is dissipated in the form of heat, and the resistors are designed to become hot during normal operation.

NOTE: This part of the system operates at around 600v DC. No part of the inverter should be touched whilst power is on, or within 10 minutes of isolating the system.

4.3 Mains power switch

The red lever switch is mounted on the right-hand cabinet. Turn the lever clockwise to connect mains power. The white indicator light on the panel will illuminate when power is on.

Once power is applied the system will run a short test sequence, this can be seen on the Display Screen on the panel door.

When the sequence is complete the screen will display normal readings. The control system will automatically be in an alarm condition, until the blue 'Reset' button on the control panel is pressed and the system becomes operational **[see Fig. 6]**.

4.4 Visual Display Screen

The screen is mounted on the front on the control cabinet. The display indicates winch status including ride height, number of flights and alarm descriptions. Balloon elevation and speed are indicated during ride operation.

A range of screens can be selected to display various functions or reset parameters.

4.5 Visual Display Screen Functions

To enable winch operation:

- Turn mains power isolator 'on'
- Turn System Key on cabinet to 'on'

The Display Screen will be illuminated while it scrolls through a Self Test Program before it is operational.

After the Test Program is complete the screen will display:

- Main Safety Relay Trip
- Winch drive fault

The audible warning will sound.
The 'Reset' button will flash blue.

To clear screen and prepare for operations:

- Release 'E-stops' (located at cabinet panel, Ground Control Box, and Winch Junction Box on gimbal pedestal)
- Press 'Reset' button on cabinet panel

Audible alarm will cease.
'Reset' button will stop flashing.

Winch is ready for operation after daily inspection.

Before operation:

- Check for 'Alarms'
- Check 'Ride Height'
- Zero daily rides.

4.6 Screen Operation

Press 'Main Screen' to display functions **[see Fig. A, 'Main Screen']**.

To set clock

[see Fig. A, 'Main Screen']

Alarms

[See Fig. B, 'Alarm Screen'.]

To delete alarms

[See Fig. B, 'Alarm Screen'.]

To zero 'Rides for Day' at start of daily operation

[see Fig. C, 'Rides Screen'.]

Ride Height

[See Fig. D, 'Ride Height Screen'.]

Zero ride height after emergency recovery

[See Figures E 'Engineering Screen' and F 'Encoder Screen'.]

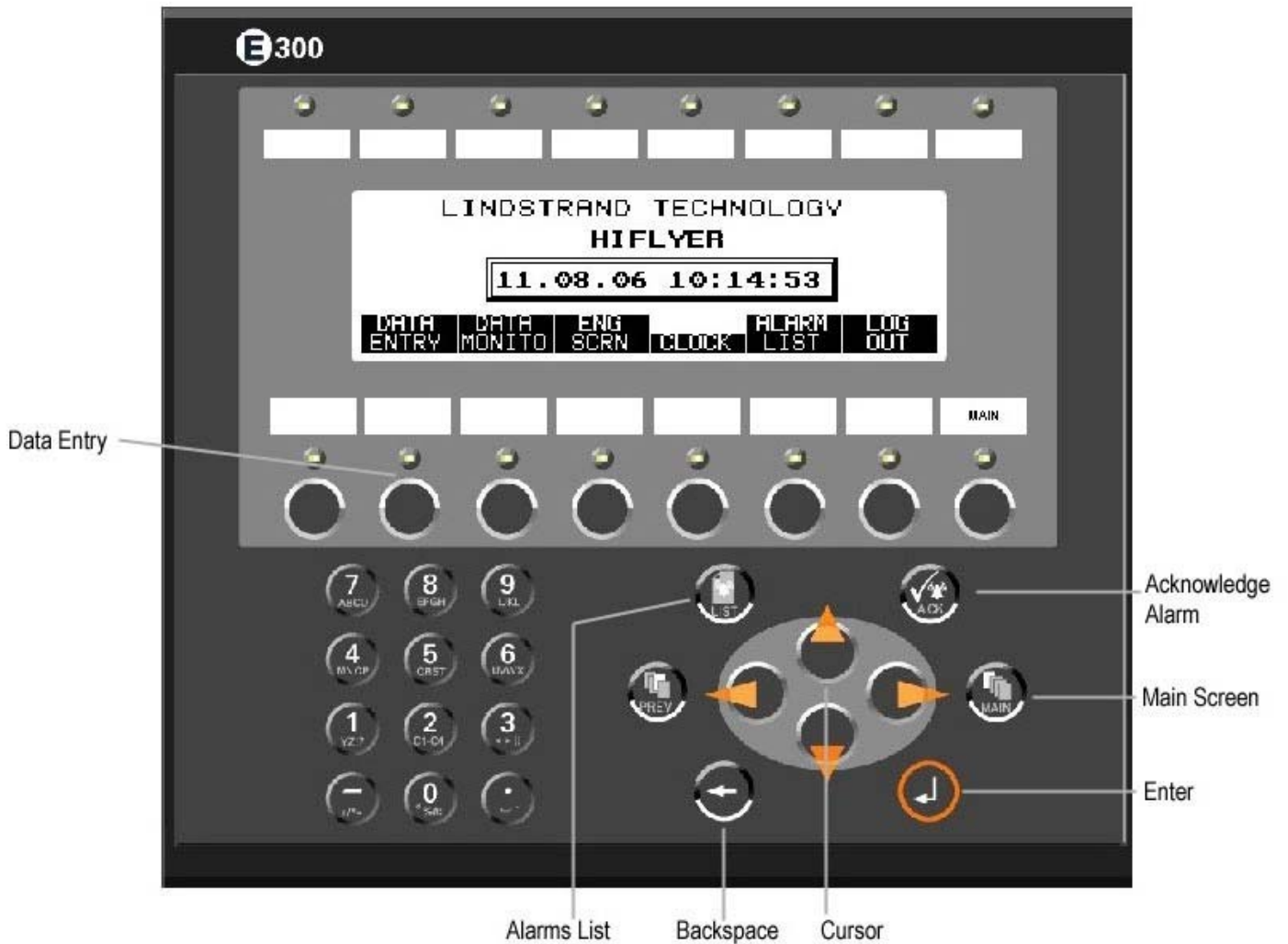

Figure A: Main Screen

To set clock

- Select 'Main Screen'
- Press 'Clock'
- Press 'Enter'
- Move cursor arrows left or right to change time
- Return to 'Main Screen'

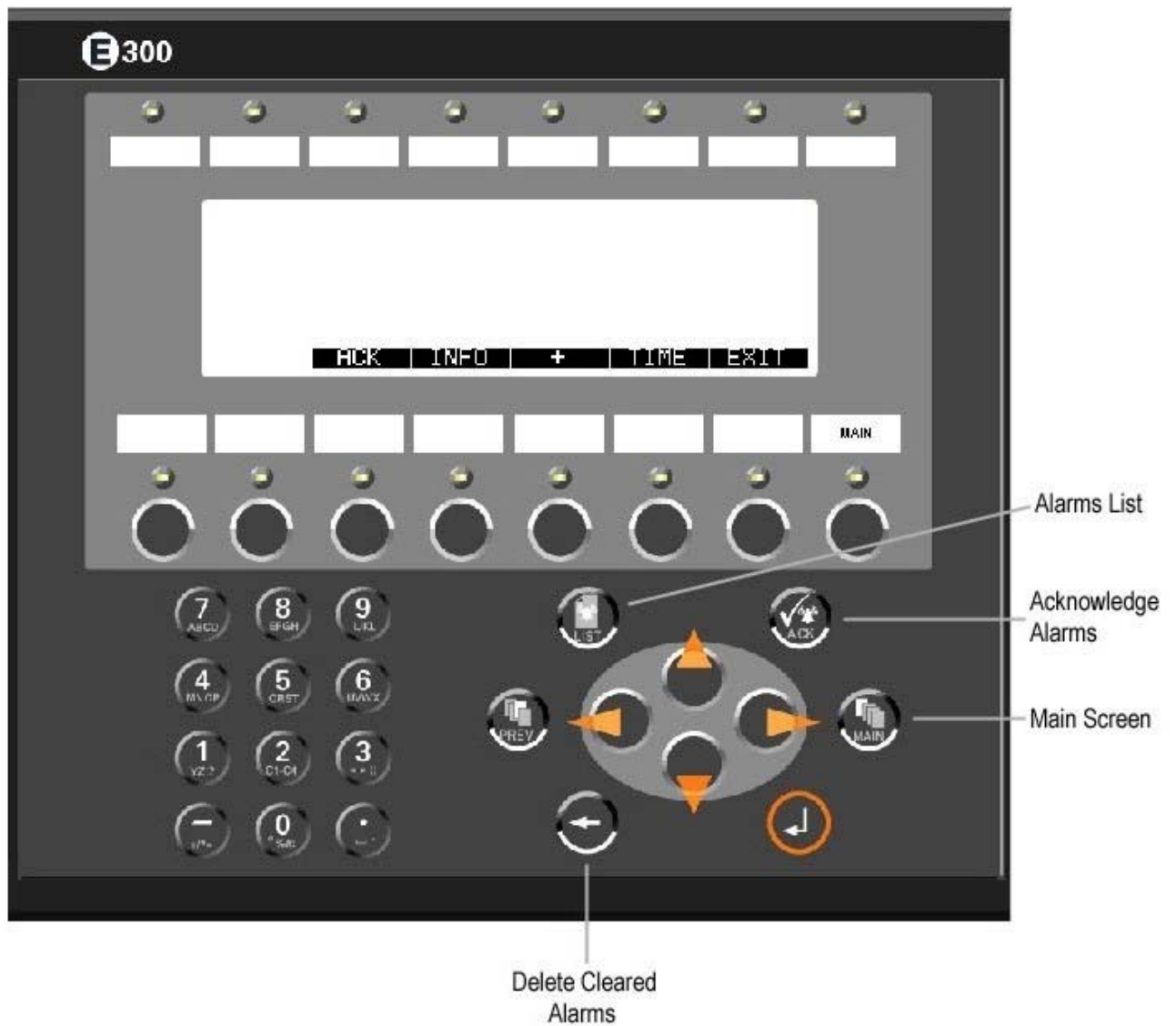

Figure B: Alarms

To display alarms

- Press 'alarm list'
- Release all 'E-stops'
- Check Alarm faults are rectified

To delete alarms

- Press 'back space' repeatedly
- Return to 'Main Screen'



Figure C: Rides Screen

To zero 'Rides for Day' at start of daily operation

- Press 'Data Entry' on Main Screen **[see Fig. A]**.
- Press 'Next' to go to Rides Screen **[see Fig. C]**.
- Press 'Reset Rides' to zero 'Rides for Day'.
- Return to 'Main Screen'.



Allows ride height selection: 20m - 160m

Figure D: Ride Height Screen

Ride Height

- Press 'Data Entry' on Main Screen [see Fig. A].
- 'Ride Height' displayed on Screen 1 [see Fig. D].
- Key in selected ride height on keypad.
- Press 'Enter'
- Return to 'Main Screen'

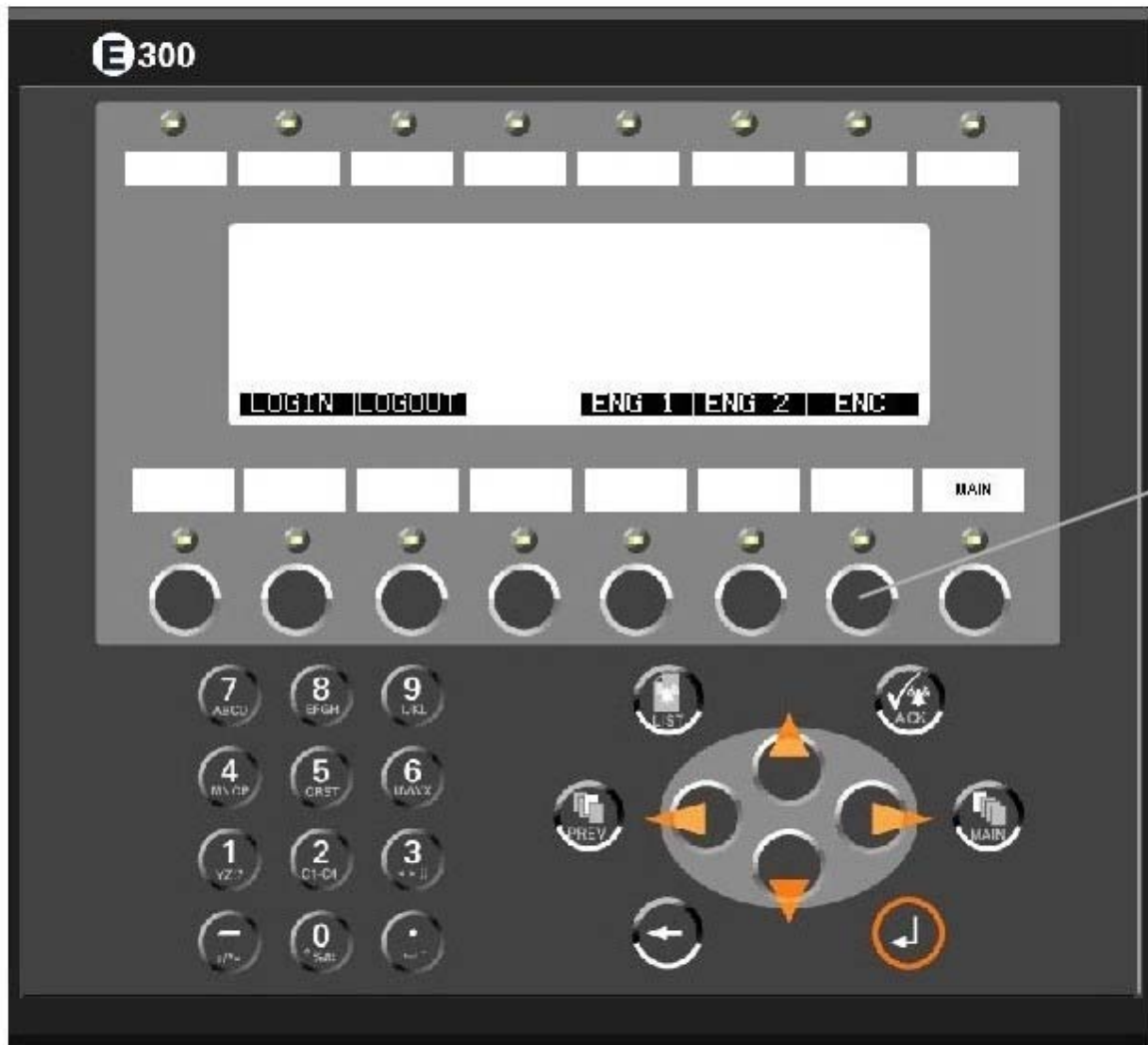

Encoder
Screen

Figure E: Engineering Screen

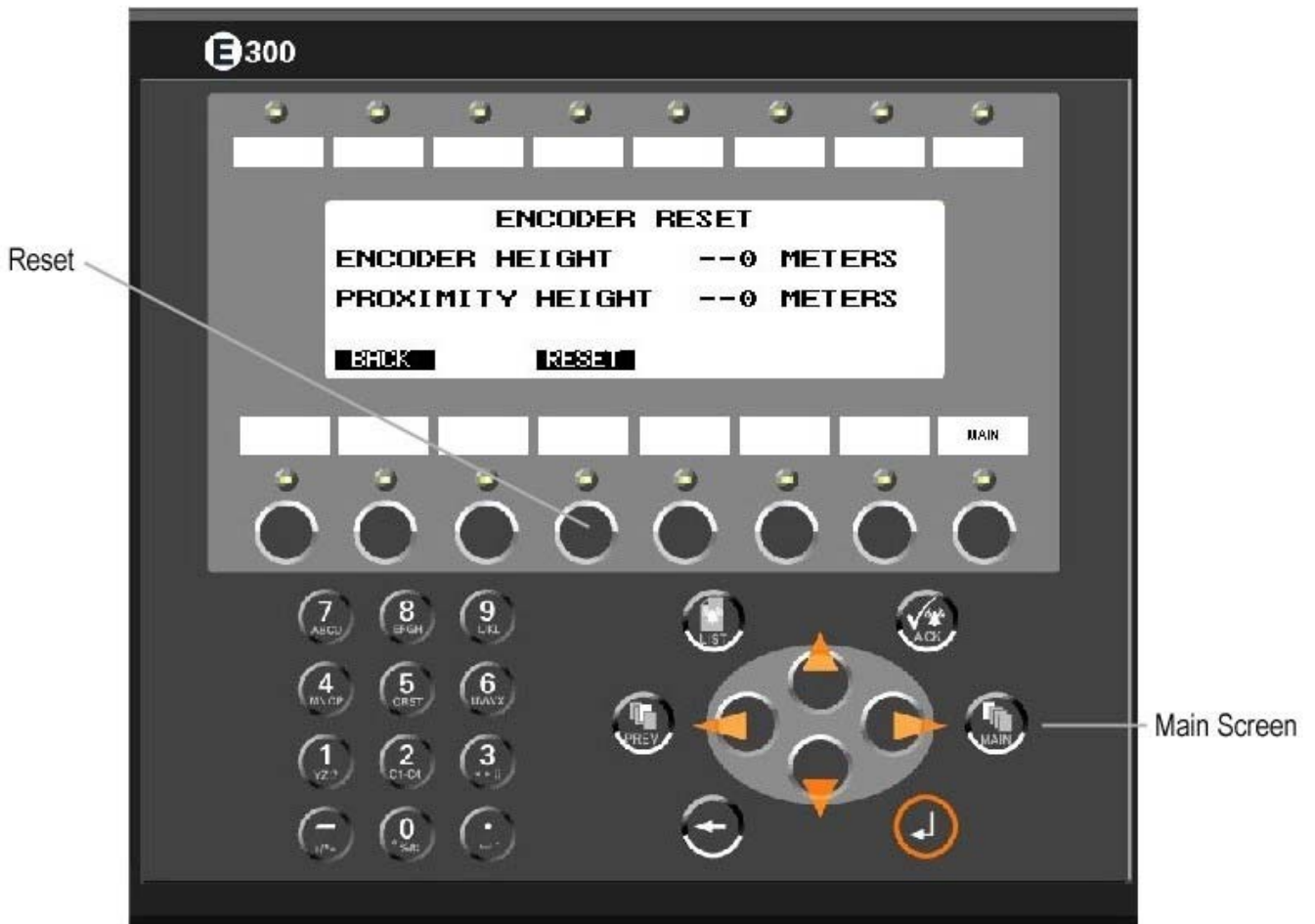

Figure F: Encoder Screen

Zero ride height after emergency recovery

- Select Engineering Screen – ‘ENG SCR’ on Main Screen **[see Figure A]**.
- Press Encoder – ‘ENC’ on Engineering Screen **[see Fig. E]**.
- Encoder screen selected **[see Fig. F]**.
- Press ‘Reset’ to zero ride height
- Return to ‘Main Screen’

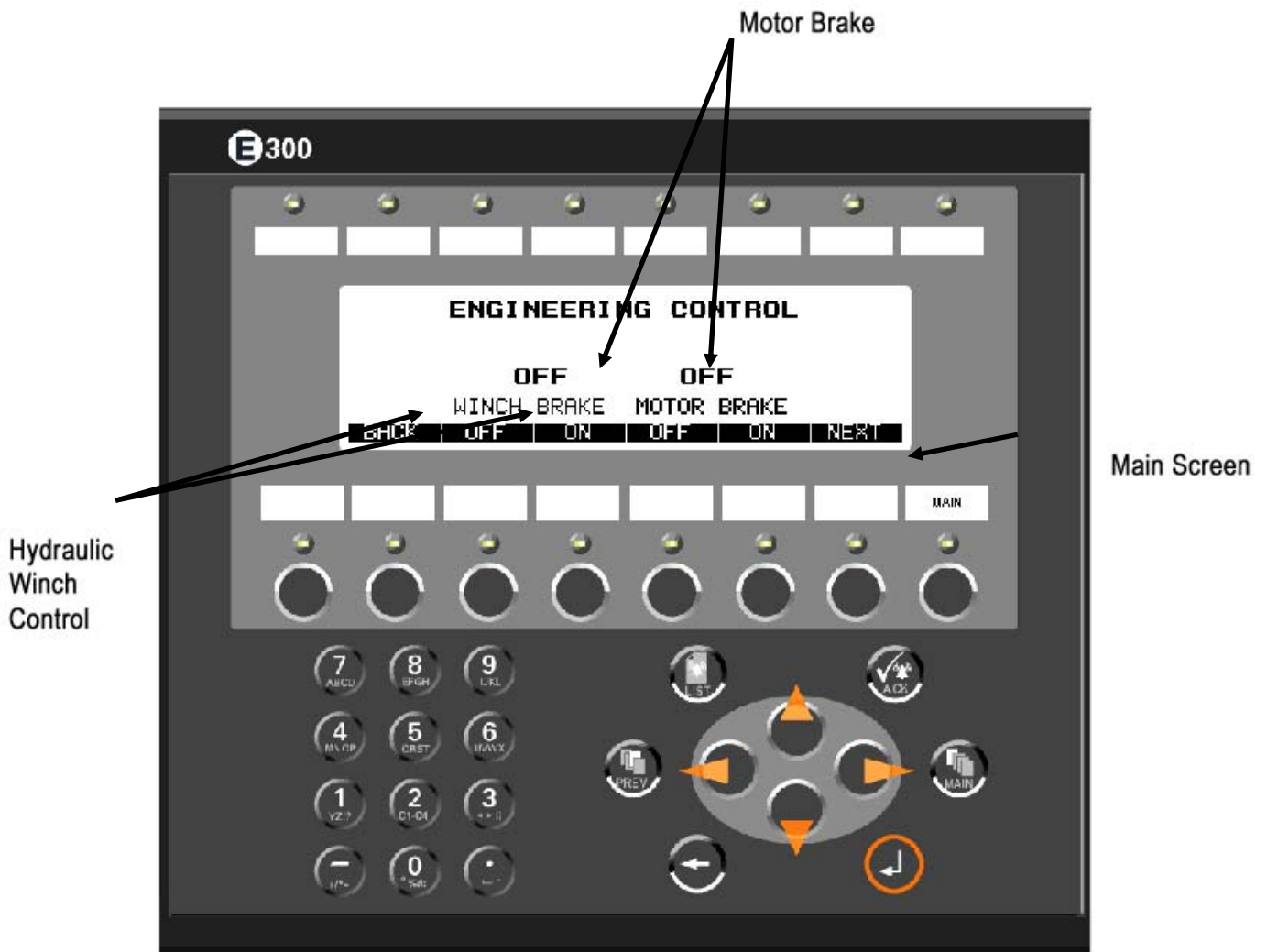

Figure G: Winch Brake Control Screen

Disengaging Brake Systems

- From Main Screen [see Figure A] select Engineering Screen ['ENG SCRIN']
- Press 'LOGIN' and enter code [see Figure F]
- Press 'ENG 1' to enter Brake Control Screen [see Figure G]
- To control hydraulic winch brake and motor brake, use 'On' and 'Off' buttons

5 OPERATION CONTROLS

The balloon ascent and descent operation can be controlled from the gondola or ground.

The **gondola control** box is mounted in the gondola instrument panel and is operated via a radio link.

The **ground control** box is located outside the landing platform where the operator has a good view of the gondola landing process. The ground control is the primary controller and priority over the gondola control can be selected.

The main winch system settings, system control panel and emergency recovery controls are in the control cabinet located in the winch pit or housing.

5.1 Gondola Control

The gondola remote radio controls and antenna are mounted on the gondola instrument panel. There are 3 control buttons and a security keyswitch.

1. Keyswitch – The controls will not function until the key is turned to ‘unlock’.
2. Up – Press and release the top green button to start the winch and ascend the balloon. The balloon will accelerate up to speed and then decelerate to a stop at the preset ride height. After the winch has stopped the motor and hydraulic disc brake will apply.
3. Stop – The middle red button will decelerate the balloon to a stop at any stage of ascent or descent.
4. Down – The bottom green button will descend the balloon from ride height or any intermediate stop. The descent will decelerate to a stop a short preset distance above the landing platform. From this height the button is not latching and must be kept depressed to continue the descent. If the button is not depressed for a period of 7 seconds the brake will automatically apply. There will be a short delay before the brakes are released when the button is pressed to continue the landing.

5.2 Ground control

The control box is located at the perimeter of the landing platform allowing a good view during the gondola landing [see Fig. 8].

The ground control has the following functions:

1. Mains on – White indicator illuminated when mains power to winch is switched ‘on’.
2. Control keyswitch – Key turned to select ‘local’ (ground) or ‘remote’ (gondola) control.
3. Emergency stop – Pressing the red ‘E-stop’ button will stop the winch and the balloon immediately with no gentle deceleration. The sudden stop will be disconcerting to passengers and the Emergency Stop must only be used in a real emergency, and tested with the balloon unmanned. To release the ‘E-stop’, twist and pull out.
4. Reset – Release all ‘E-stops’ and press the blue ‘Reset’ button to enable the system. The blue reset button on the main control panel on the control cabinet will be illuminated. The system is reset ready for operation.

5. Control buttons – The 3 control buttons – yellow ‘up’, red ‘stop’ and blue ‘down’ – are used to raise, lower, stop and land the balloon as in the gondola control **[see Section 5.1.]**

When the control is unattended or the balloon moored, the ‘E-stop’ should be applied to prevent accidental operation.

6 WINCH SYSTEM FAILURES

If a fault occurs during operation an 'E-stop' will be triggered and an alarm raised.

The audible alarm will sound, the blue 'reset' light on the control cabinet will flash, and the blue reset and red alarm on the ground control box will flash.

To identify the fault on the visual display screen:

- Select Alarm list
- The alarm fault will be displayed

If the fault can be rectified descend the balloon and establish the cause before further operation.

Potential faults and recovery procedures follow:

6.1 Gondola Control Failure

The winch control unit is mounted in the gondola control panel. Signals from the gondola are relayed to the winch. If the gondola control fails to operate:

1. Inform ground operator by radio
2. Switch ground control unit from 'GONDOLA' to 'GROUND'
3. Operate the balloon from the ground station
4. Identify and repair fault as soon as balloon is out of operation

6.2 Mains Power Supply Failure

The winch will stop, leaving the balloon elevated.

The balloon can be recovered using the auxiliary motor with generator power [see **Appendix 7 for condensed procedure to be displayed in winch pit.**]

During the following emergency recovery procedure the operator is the final, fail-safe link in the operation, and should double-check all functions throughout the recovery. If in doubt about any function, the recovery should be stopped, the manual consulted and a second opinion sought. Only after the potential problem has been cleared should the recovery be continued.

The Program Logic Controller (P.L.C.) will not monitor the balloon height during the descent and the winch will not stop automatically after the gondola is landed.

The operator must stop the cable disc descent at the normal position before it contacts the gimbal trigger switches.

Auxiliary Motor and Generator Recovery:

- Keep balloon operator informed over radio.
- Balloon operator should calmly inform passengers that slower than normal descent (approximately 12 mins from 120m) is underway.
- Isolate main winch system with 'E-stop' on main control panel door.
- Release catches on auxiliary motor pinion cover and open cover. This will disable the auxiliary motor and main motor drive.
- Turn auxiliary motor handwheel to align pinion gear teeth with drum gear.

- Lift plunger pin on pinion and slide pinion into mesh with drum gear until plunger pin locates into motor shaft. 'Coupling Engaged' indicator will illuminate [see Fig. 4].
- Close pinion cover door and latch shut.
- Check generator breaker is 'off'
- Start generator.
- Switch generator breaker 'on'.
- Turn supply keyswitch to 'generator'.
- Turn 'Operation Mode' keyswitch to 'emergency'.
- Check personnel are clear of winch.
- Check all 'E-stops' are released.
- Press 'Reset' button.
- Check 'Clear to Run' and 'Coupling Engaged' indicators on.
- Press 'Auxiliary Start' button
- Disc and motor brakes released, drum rotates, balloon descends.
- **If motor fails to start see Section 6.3.**
- Monitor balloon descent until gondola is landed.
- Press 'Auxiliary Stop' button when cable disc reaches normal stop position, approximately 300mm above gimbal 'trigger switches'.
- Press 'E-stop'.
- Disembark passengers
- Turn mains/generator keyswitch to 'mains'.
- Switch generator breakers 'off'.
- Stop generator.
- Open auxiliary motor pinion cover.
- Pull pinion 'plunger pin' and slide pinion back to disengage gear, until 'plunger' relocates in shaft.
- Close and latch pinion cover.
- Return 'Operation Mode' keyswitch to 'Normal'

After passengers have disembarked check all systems are reset for mains operation.

After mains power is restored, zero ride height and make unmanned test ride.

If the winch cable disc is inadvertently winched down onto the gimbal trigger switches an 'E-stop' will activate. Release the 'E-stop' as detailed in **Section 6.4**.

6.3 Auxiliary Pinion Cover Override

During auxiliary motor recoveries the pinion drive is engaged and the safety cover closed. Closure of the safety cover should reconnect the 'E-stop' circuit.

If the closure fails to re-connect the circuit, a 'coupling guard open' fault will be displayed.

To override the fault the recovery circuit can be connected by turning and holding the 'Auxiliary Coupling Override' switch, which is located above the cable entry on the side of the control cabinet.

6.4 'E-stop' locked by Cable Disc

During emergency recovery the winch has to be manually stopped at the correct level normally triggered by the 'photo eye' proximity switch. If the stop is left too late the cable disc will descend onto the overtravel switches on the gimbal sheave triggering an 'E-stop', which will then remain locked on by the disc.

The indications of an 'E-stop' lock are:

1. Cable disc contacting overtravel switches.
2. Disc overtravel 1 and 2 activated.
Safety relay activated.
3. 'WINCH NOT ENABLED' on display panel.
4. Winch will not 'RESET'.

N.B. Do not attempt to lift disc off overtravel switches by releasing brakes.

Procedure to release 'lock':

1. Mark position of disc on cable with tape.
2. Unscrew disc clamping screws.
3. Slide disc up cable to clear trigger switches.
4. 'RESET' winch.
5. Raise balloon approximately one metre.
6. Stop.
7. Slide disc down cable to marked position.
8. Reclamp disc.
9. Press descend button on ground station.
10. Make unmanned test ride.

6.5 Mains and Generator power failure

BE PREPARED!

The generator must be regularly serviced, tested daily and be ready to run with a charged battery and fuel in the tank.

A battery charger and container of clean fuel must be on site.

Have telephone numbers for:

- The electricity supply company
- The generator service agent
- A mobile generator service company

on display near the generator.

Recovery procedure in the unlikely event of combined mains and generator power failure:

- Keep the balloon operator informed over the radio.
- The operator should calmly inform the passengers that actions are underway to restore power.
- Call the electricity supplier to find out when power will be restored.
- If generator battery is flat change it for a charged or new battery.
- Check fuel level and top up if low.
- Prime fuel system.
- If generator will not run:
 - Call service agent to site urgently
 - Call mobile generator service to supply: 380 - 415vac, 3 phase 20 kVA, 28 amp peak generator
 - Call in off-duty crew

Emergency Services

It is probable that passengers will call the emergency services even before the event has become an emergency.

The emergency services should be informed of the situation and that it is under control.

If the emergency services appear on site whilst the situation is under control, delegate a crew member to calmly inform them of the full situation and explain the actions being taken to recover the balloon and passengers.

Ask for their help with reconnecting the mains supply, and getting a mobile generator on-site.

Passenger Care

If the balloon descent is delayed for a long period, or the balloon operator informs the ground crew that any passenger is suffering from a problem, an ambulance and paramedics must be called to the site. If necessary, supplies can be reeled up to gondola.

Mains power restored

Descend balloon normally [**see Section 5.2**].

Generator power restored

Descend balloon with auxiliary motor [**see Section 2.7**].

6.6 Main Motor Brake locks 'ON'

The main motor brake is a 'fail safe' brake that is released by mains power (or auxiliary generator) as directed by the control unit. Power failure, or disruption of supply from the control unit will de-energise the brake which will be applied 'on' under spring pressure, stopping the motor and balloon travel.

Do not attempt to recover the balloon with the auxiliary motor, if the main motor brake is applied. The brake cannot be overridden and severe damage could be caused.

To release the main motor brake:

1. **Ensure that the hydraulic drum disc brake is applied** and get another operator to confirm
2. Press 'E-stop'
3. Undo the 4 fan and brake cowling retaining bolts with a 13mm spanner.
4. Remove the cowling from the back of the main motor
5. The brake and fan will be exposed
6. Back off the 3 brake holding nuts at back of brake plate (2 turns with 22mm spanner)
7. The fan will be able to be turned by hand when the brake is freed 'off'
8. Release 'E-stop'
9. **Do NOT ascend balloon**
10. **Descend** balloon under main or auxiliary motor power
11. Disembark passengers & low-moor balloon
12. Tighten 3 brake screws
13. Ground balloon until fault has been rectified

14. Inform Lindstrand Technologies Ltd of failure, and have brake checked and approved by LTL engineer before operating the balloon with passengers

6.7 Hydraulic disc brake locks 'ON'

The hydraulic brake is a fail-safe brake that is held open ('off') by electrically controlled hydraulic pressure. Failure of the electric system or hydraulic pressure will cause the brake to apply under spring pressure, stopping the drum and balloon travel.

In case of the brake failing 'on':

6.7.1 Electrical System Fault

- Press 'E-stop' on ground or winch control
- Turn hydraulic valve hand lever (adjacent to pressure gauge) 90° from 'automatic' to 'manual'
- Close the valve at the bottom of the hand pump by turning clockwise until tight
- Pump the handle until brake pads visibly lift off drum disc
- Release 'E-stops'.
- 'Reset' system
- Descend balloon normally
- Disembark passengers & low moor balloon
- Open hand pump valve – brake applies
- Return hydraulic hand lever to Automatic
- Check hydraulic fluid level
- Bleed system
- Check winch control system and rectify any faults
- Ground balloon until fault has been rectified
- If fault cannot be identified or rectified, inform Lindstrand Technologies Ltd and have brake checked and approved by an LTL engineer before operating balloon with passengers.

6.7.2 Hydraulic System Fault

In case of hydraulic hose failure then the hose should be replaced, the system bled and then carry out the hand pump method as in section 6.7.1

In the unlikely event of hydraulic system failure then the brakes can be manual retracted by the following method.

- Press 'E-stop' (May already be offline due to motor over current)
- Liberally grease bolt, thread and washer on the brake caliper.
- Tighten caging bolt to cage spring. (Do not use impact wrench)
- Perform key switch recovery procedure, (Section 6.8)
- When Hiflyer is fully moored loosen caging bolt to reapply brakes.

6.8 Winch Control Inoperative

The winch will not respond to gondola or ground controls.

The Programmable Logic Controller (P.L.C.) is disabled and the display screen is blank.

The balloon should be recovered with the main motor under mains power at reduced speed [**see Appendix 7 for condensed procedure to be displayed in winch pit.**]

During the following emergency recovery procedure the operator is the final, fail-safe link in the operation, and should double-check all functions throughout the recovery. If in doubt about any function, the recovery should be stopped, the manual consulted and a second opinion sought. Only after the potential problem has been cleared should the recovery be continued.

The Program Logic Controller (P.L.C.) will not monitor the balloon height during the descent and the winch will not stop automatically after the gondola is landed.

The operator must stop the cable disc descent at the normal position before it contacts the gimbal trigger switches.

Keyswitch Recovery:

- Keep balloon operator informed over radio
- Balloon operator should calmly inform passengers that slower than normal descent is underway (approximately 12 mins from 120m)
- Check personnel are clear of winch
- Turn operation 'ops mode' keyswitch to 'emergency'
- Press 'Reset' button
- Allow approximately 20 seconds for drive to come 'on line'
- Turn 'emergency recovery' keyswitch to 'emergency' and hold in position for the duration of the descent. Releasing the key will stop the drive [**see Note 1**].
- Brakes will release and the balloon descend
- Check balloon is descending not ascending
- **If the balloon ascends release keyswitch immediately and press 'E-stop' [see Note 2]. After brakes are applied release 'E-stop', press reset and try keyswitch again after 20 seconds. Resetting the system will allow the balloon to descend.**
- Release the keyswitch when the cable disc reaches normal stop position approximately 300mm above gimbal trigger switches
- Balloon will stop and brakes apply
- Press 'E-stop'
- Turn 'operation mode' keyswitch to 'normal'
- Zero ride height [**see Section 6.10**].

Note 1: If the 'Emergency Recovery' keyswitch is released and returns to 'normal', the drive system must come to a complete stop before the keyswitch is returned to 'emergency' to continue descent.

Note 2: Because the automatic 'E-stop' circuit is partially disabled with operation keyswitch in 'emergency' it is possible for the main drive to trip out, allowing the balloon to ascend.

After the passengers have disembarked the balloon must be low-moored. The fault should be identified and rectified, and the system tested with the balloon unmanned.

Inform Lindstrand Technologies Ltd of the failure and have the rectification approved by an LTL engineer.

If the winch cable disc is inadvertently winched down onto the gimbal trigger switches an 'E-stop' will activate. Release 'E-stop' as detailed in **Section 6.4**.

6.9 Main motor disabled

In the event of the main control or motor drive failure the balloon should be recovered using Mains power and the Auxiliary Motor [see **Appendix 7 for condensed procedure to be displayed in winch pit.**]

During the following emergency recovery procedure the operator is the final, fail-safe link in the operation, and should double-check all functions throughout the recovery. If in doubt about any function, the recovery should be stopped, the manual consulted and a second opinion sought. Only after the potential problem has been cleared should the recovery be continued.

The Program Logic Controller (P.L.C.) will not monitor the balloon height during the descent and the winch will not stop automatically after the gondola is landed.

The operator must stop the cable disc descent at the normal position before it contacts the gimbal trigger switches.

Auxiliary Motor and Mains Power Recovery:

- Keep balloon operator informed over radio.
- Balloon operator should calmly inform passengers that slower than normal descent (approximately 12 mins from 120m) is underway.
- Isolate main winch system with 'E-stop' on main control panel door.
- Release catches on auxiliary motor pinion cover and open cover. This will disable the auxiliary motor and main motor drive.
- Turn auxiliary motor handwheel to align pinion gear teeth with drum gear.
- Lift plunger pin on pinion and slide pinion into mesh with drum gear until plunger pin locates into motor shaft. 'Coupling Engaged' indicator will illuminate [see **Fig 4**].
- Close pinion cover door and latch shut.
- Turn 'Operation Mode' keyswitch to 'Emergency'.
- Check personnel are clear of winch.
- Release all 'E-stops'.
- Press 'Reset' button.
- Check 'Clear to Run' and 'Coupling Engaged' indicators on.
- Press 'Auxiliary Start' button.
- Disc and motor brakes released, drum rotates, balloon descends.
- Monitor balloon descent until gondola is landed.
- Press 'Auxiliary Stop' button when cable disc reaches normal stop position – approximately 300mm above disc overtravel switches.
- Press 'E-stop'.
- Open auxiliary motor pinion cover,
- Pull pinion 'plunger pin' and slide pinion back to disengage gear, until plunger relocates in shaft [see **Fig. 4**].
- Close and latch pinion cover.
- Return 'Operation Mode' keyswitch to 'Normal'.
- Zero ride height [see **Section 6.10**].

After the passengers have disembarked the balloon must be low-moored. The fault should be identified and rectified, and the system tested with the balloon unmanned.

Inform Lindstrand Technologies Ltd of the failure and have the rectification approved by an LTL engineer.

If the winch cable disc is inadvertently winched down onto the disc overtravel switches an 'E-stop' will activate. Release 'E-stop' as detailed in **Section 6.4**.

6.10 Ride Height Zero

During emergency recovery procedures, the P.L.C. does not register the ride height.

As a result the winch will not stop automatically, and after the manual stop the ride height will not be zeroed.

Before any further flights the ride height must be zeroed.

The ride height is returned to zero by the following display screen functions:

- Select Engineering screen – 'ENG SCR'N'
- Press Encoder – 'ENC'
- Press 'Reset'
- Ride height zeroed
- Return to Main Screen

6.11 High Wind Recovery

In case of recovery in high winds, severe buffeting can lead to cable distortion and snatch which can contact the disc overtravel switches and activate an 'E-stop' during the crucial recovery and landing stage.

To override the 'E-stop' during the recover a second keyswitch is located on the junction box attached to the gimbal pedestal. This location allows a good view of the descending gondola during the vulnerable landing stage.

The balloon can now be recovered with the ground control box.

7 BALLOON MOORING SYSTEM

When not in operation the balloon must be securely moored. See *Lindstrand Technologies Ltd Flight Manual* (LTL TAFM), Sections 3.4.7 and 3.4.8.

The balloon envelope is pulled down and secured onto the mooring ring on top of the gondola frame by an inner and outer circle of mooring winches.

7.1 Mooring Winch Location

The mooring winches are disposed in two rings centred around the middle of the landing platform and mounted on top of concrete mooring blocks.

The inner ring consists of 16 mooring winches spaced equidistantly on a 23 metre circle directly below the equator rope of the envelope net from which 16 inner mooring ropes are suspended.

The outer ring consists of 4 mooring winches and 12 ratchet strap mooring points spaced equidistantly on a 50 metre circle. The outer moorings are attached to mooring ropes from the polar rope around the crown of the envelope.

7.2 Mooring winches

20 mooring winches are supplied for each site.

The winches consist of 1.5kW geared motors driving rope drums.

The motors are powered from the 3-phase mains supply.

Each motor has an isolator box with an 'on/off' selector and a push button switch to activate each winch independently.

7.3 Mooring winch control

The mooring winch control system is located in the left hand compartment of the winch control cabinet **[see Fig. 6]**.

The mains power 'on/off' isolator switch and red 'overload tripped' warning light are mounted in the left hand cabinet door.

The mooring system operates independently from the main winch system.

The mooring winches are collectively controlled from a pendant control unit on the end of a 10 metre wander lead which allows the operator to monitor the field of operation.

7.4 Pendant control unit

With mains power isolator 'on' and all mooring winch isolator box switches 'on', the mooring system is controlled from the pendant control unit **[see Fig. 9]**.

The control functions are as follows:

7.4.1 'E-stop' and Reset Button

The 'E-stop' is located in a shroud at the end of the pendant controller. Pressing the button will stop the complete mooring system.

To restart the system twist the button to release and press the blue restart button.

The blue indicator lamp adjacent to the reset should illuminate and the system be ready to operate.

7.4.2 Raise/Lower switch

The raise/lower switch changes the rotation of the mooring winches to raise (unmoor) or lower (moor) the balloon.

7.4.3 Moor Outer – controls

The 'Moor Outer – One/All' switch will select the operating mode of the four outer mooring winches.

When set to 'One' the winches are individually controlled from the push button at each winch. This function is used to equalise tension on each mooring rope.

When set to 'All' the outer winches are controlled in unison with the 'Moor All – Outer' push button.

7.4.4 Moor Inner – controls

The 'Moor Inner – One/All' switch will select the operating mode of the 16 inner winches.

When set to 'One' the winches are individually controlled from the push button at each winch. This function is used to equalise tension on each mooring rope.

When set to 'All' the inner mooring winches are operated in unison with the 'Moor All – Inner' push button.

7.4.5 Overload Tripped Warning

The trip warning lamp indicates that the safety relay is activated.

Release the Pendant Control 'E-stop' and 'Reset' at the pendant. If the warning lamp is still illuminated:

- Turn mooring winch power 'off' at left hand cabinet door panel
- Open door
- Check all circuit breakers
- Remake any open breaker
- Close door
- Turn on mooring winch power
- Reset at pendant

Fault finding can be aided by reference to 'Balloon Mooring' section of the *Electric Circuit Diagram* pack.

8 ELECTRICAL SYSTEMS

8.1 Air Conditioning Systems

The air conditioning unit is fitted to systems, which are located in areas with ambient temperatures over 40 degrees Celsius or high humidity levels. The unit is set to keep the ambient temperature below 40°C; it does not cool the system much below this. In areas with high humidity the purpose of the unit is to stop moisture developing within the control panel, if the unit is set to run under the dew point temperature a possible problem is that when the doors are opened the air will condense on the components, which could result in serious damage.

Faults with the air conditioning unit are not detected by the control system, and could result in overt temperature alarms activating on the main inverter, but most likely would not result in any problems. For this reason the units operation should be checked on a monthly basis.

8.2 110v Transformer (TX2)

This transformer supplies the 110v control voltage for the whole of the system when running in normal mode. Failure of this transformer would result in total loss of all system functions and only ancillary equipment such as the fans, air conditioning and hydraulic brake motor will function.

The transformer supply is then split into several circuits, which are fed from MCBs within the main panel.

8.3 K30 and K31

These two relays are used to select between mains and generator supply. These relays are connected so that it is not possible to energise them both at the same time. If this were to happen there would be a risk of crossing the mains and generator supplies, which could lead to serious damage to the control system.

There are two breakers in-line with each supply (Q30 and Q31). If these breakers are tripped the power to all 3-phase devices will be lost, however, the control system will still function as the 110v supply is taken before these breakers.

Failure of one of these relays would result in loss of either mains or generator supply.

8.4 110v Transformer (TX3)

This transformer has the same function as TX2, except that it does not supply the PLC system with power. While on the generator supply it is only possible to operate the auxiliary motor, and for that reason this transformer will only supply 110v to the parts of the system required for an auxiliary recovery. Having a separate transformer also gives the system a backup should TX2 fail.

8.5 Brake Hydraulic Motor

The hydraulic motor is the electric motor mounted on the top of the hydraulic power pack used to release the hydraulic disc brake on the main drum. This motor should be rotating all the time that the brakes are applied. When the brakes are energised (SOL1 & SOL2) to allow the winch to move, the hydraulic pressure builds up to 100 BAR at which point a sensor (PS1) de-energises K33, which turns

off the motor. Should the pressure then drop below 80 BAR, PS1 will then reactivate K33 and build the pressure up to 100 BAR again.

The motor is protected from overload by the breaker Q33. Failure of any components within this circuit will result in the system not being able to remove the hydraulic brakes on the main drum.

8.6 Auxiliary Motor

The auxiliary motor is mounted at the rear of the winch, and is used to recover the winch in the event of a power failure, or a main system failure. The motor is protected from overload by breaker Q32, and is activated by the relay K32. The auxiliary motor control circuit activates this relay.

Failure of any components in this circuit would result in the auxiliary motor being inoperable.

8.7 Brake Unit

The brake unit is the electrically operated brake on the main motor. The brake is applied when K34 is not energised. The unit is protected by the overload Q34. Failure of any components in this circuit would result in the main motor brake not being released.

8.8 Winch Blower Motor

The winch blower motor is the motor which operates the fan on the main motor. The fan only operates when the inverter is on line, and is operated by the relay K35. The motor is also protected by the overload Q35. Failure of the breaker is reported to the PLC, however, failure of the relay would not be detected and may result in the inverter tripping on over temperature.

8.9 24v DC Power Supply

The 24v DC power supply is a transformer from 110v AC to 24v DC. The supply to the unit is from TX2 or TX3 and the MCB CB15 protects the unit. 24v DC is then supplied through MCB CB16 to the 24v devices. Failure of this device would result in the overspeed unit becoming inoperable (which is part of the 'E-stop' circuit) and therefore total loss of the system.

8.10 24v DC Health K44

This relay detects the 24v DC supply and is part of the 'E-stop' circuit.

8.11 Drum Speed Monitor

The speed monitor is a complex fail-safe device, which monitors the speed of the main drum by means of the encoder mounted on the side. Should the speed of the drum exceed approx. 120% of the normal running speed, the unit will trip and the 'E-stop' circuit will activate.

Three LEDs indicate the units status:

- Power: 24v DC is being supplied to the unit
- Standstill: The main drum is not rotating
- Speed: This light activates when the drum rotates too fast.

Due to the safety critical nature of this device, coupled with the fact that the end user cannot check its operation, no attempt should be made to repair or re-configure this device.

WARNING:
This item forms part of a safety critical circuit. It is recommended that only persons authorised by LTL conduct maintenance on this item.

8.12 Pay-out Proximity Sensor

This is the sensor mounted on the side of the winch which detects when one of the holes in the side of the drum passes the end of the sensor. Whilst the sensor is not detecting metal (i.e. the sensors is over a hole) the relay K60 is de-energised. When metal is detected the relay energises.

To aid in fault finding there is also an LED on the back of the sensor mounted in the winch. If the system detects a failure on this switch the ride will stop and will only descend. The ride will not function until the fault is rectified.

8.13 Balloon parked photo eye

The sensor is mounted next to the exit roller assembly on the top of the gimbal sheave, when the aluminium disc is within 300mm the sensor is activated and K62. The relay reports back to the PLC that the balloon has landed and reset the height to zero. Failure of the switch will result in the disc activating the overtravel switches, 'e-stopping' the system. This sensor is only activated when the balloon height is below 8m.

8.14 Emergency Stop Circuit ('E-stop')

This circuit is the backbone of the electrical system. Unless this circuit is healthy the majority of the system will be non-functional. The centre of the 'E-stop' circuit is the Pilz Emergency Stop Relay (ESR). Once healthy this unit will activate the 110v control circuits, and only then will any winch operation take place.

The circuit can be split into three areas, as follows:

8.14.1 'E-stop' Loop

The hard-wired 'E-stop' loop uses 2 channels passing through each 'E-stop' and limit switch. Two contactors are used in each switch to ensure that a fault on one of the contactors does not result in the switch becoming inoperable. There are 8 'E-stop' sensors on the winch, which are shown on the table below.

Switch Name	Location	Function
Control Panel	Main Panel Door	Push in Emergency
OP Station	Ground Control Station	Push in Emergency

Disc overtravel 1	Top of Gimbal Sheave	Trip if hit by aluminium disc
Disc overtravel 2	Top of Gimbal Sheave	Trip if hit by aluminium disc
Rope overtravel	Main frame opposite control panel	Trips if too much rope payed out
Fleeting sheave over pay-in	Next to fleeting sheave	Trips if fleeting sheave out of position
Fleeting sheave over pay-out	Next to fleeting sheave	Trips if fleeting sheave out of position
Main winch junction box	Top of main winch junction box	Push in emergency

Both channels have to be closed to allow the ESR to reset. When the circuit has passed through the hard wired switches, it then returns to the control panel and checks on the system status.

Relay K58 reports on the status of the PLC. If the PLC is not functioning correctly, or the PLC program has detected a fault, this relay will open.

Relay K65 detects the status of the drive. This relay differs slightly as the contacts are normally closed, and open if the drive detects a fault. The reason for this is that when the 'E-stop' circuit is tripped the drive is shut down. If normally open contactors had been used it would not be possible to reset the system with the drive not turned on.

K44 reports if the 24v DC supply is present. If 24v DC is lost then the relay will open and break the loop.

In case of a fault on any of the above relays, the emergency operation keyswitch on the main panel is used to link these out of the 'E-stop' circuit. This will allow the auxiliary motor to recover the balloon should there be an internal fault. However, all other limit switches will still function.

8.14.2 Relay Check Circuit

As well as the main 'E-stop' loop there is also a second loop, which must be closed before the ESR can be reset. This loop checks the status of 4 relays to ensure that the contacts have not been welded (i.e. the relay is stuck permanently on). The relays checked are as follows:

- K36 supplies power to the inverter
- K32 activates the auxiliary motor
- K34 activates the motor brake
- K42 activates the hydraulic brakes

8.14.3 Reset relay

When either of the two reset buttons is depressed, K50 is activated and closes the switch between S33 & S34 on the ESR. Providing the 'E-stop' loop and the relay check circuits are closed the relay will activate and close the contacts within the ESR. These contacts supply voltage to the control systems and will allow operation of the winch system.

8.15 Mains 'On' light

When 110v is supplied the two lights will illuminate. Note that these lights only function from the 110v supply. If there were a failure of TX2, the light would not illuminate, even though there is a 3-phase supply present.

8.16 Reset push buttons

When either of the two 'reset' buttons are pressed this operates the relay K50 and closes the reset loop on the ESR. As can be seen from the configuration of this circuit, there is no difference between these two buttons, and it is therefore irrelevant which button is used.

Once the ESR has reset or the lamp test button has been pressed, the reset button will illuminate.

8.17 Lamp test button

When pressed this will activate K51, which in turn supplies voltage to all indication lamps on the panel. This allows the user to check if all of the lamps are functioning.

8.18 Winch Drive enable

Providing the following conditions are true:

- ESR is reset
- Breaker Q36 is not tripped
- K52 (Auxiliary Coupling Detection Prox) is closed
- K31 (mains power selector) is closed

K36 will energise. This contactor supplies power to the inverter. Failure of this relay will result in no power being supplied to the inverter and no operation of the ride in normal mode. (Auxiliary recovery will still be functional).

8.19 Winch blower

Providing the following conditions are true:

- ESR is reset
- K36 is closed
- Q35 is not tripped

K35 will activate and turn on the fan on the main motor.

8.20 Brake Solenoid 1 & 2 (K42)

When activated these two solenoids allow the hydraulic system to pressurise. Providing the ESR is reset, K42 is energised, and fuses F3 and F4 are ok, the solenoids will activate and release the brakes.

8.21 Auxiliary Motor Activation

This circuit checks that the auxiliary motor is clear to run. The keyswitch has to be in emergency mode, Q31 (Mains) and Q30 (Generator) must not be tripped; this will activate K53 to show the auxiliary motor is clear to run.

8.22 Auxiliary Motor Run

Providing the ESR, K32 is energised the motor can be started or stopped by pressing the relevant button. The circuit energises K43 which will start the motor, remove the motor brake (K34) and the hydraulic brakes (K33).

8.23 Normal/Recovery Keyswitch

This key switch is used to recover the balloon in the event of a system failure where the inverter and brake systems are still functional. When energised this circuit will activate K40 and K55 and also send a run signal to the inverter.

8.24 Hydraulic brake activation

This circuit is split into 4 legs; the first leg is used during normal operation. Providing K64 (Drive Enable) and K59 (PLC Output) are energised, K42 will energise and operate the hydraulic brake solenoids. The 2nd and 3rd leg is used by the normal/recovery keyswitch and the 4th leg is used when the auxiliary motor is started.

8.25 Pressure Switch (PS1)

This switch monitors the pressure of the hydraulic system and is mounted on the hydraulic power pack. Once the set pressure (100 Bar) has been reached the switch opens and K33 is de-energised, this switches off the hydraulic motor. Once the pressure drops below approximately 80 Bar the motor is re-activated. It is quite normal for the pump to cycle on and off a couple of times per ride, but if this becomes more frequent it could indicate a hydraulic leak.

8.26 Coupling Engaged Proximity Sensor

This proximity sensor is mounted to the side of the auxiliary coupling. Its function is to determine if the coupling is engaged. When the coupling is disengaged (system running in normal mode) the circuit is closed and K52 is energised. This allows power to the inverter. When the coupling is engaged the power to the inverter is cut and the auxiliary systems are enabled.

8.27 Coupling engaged lamp

When K52 is energised or the Lamp Test button is pressed this light will illuminate.

8.28 Invertor

The invertor is the device which controls the main motor. If this device is not functioning correctly there will be no system operation except for the auxiliary motor.

8.28.1 Power Supply

Power is supplied to the unit from the main isolator through a fused 100A isolator, then Q36 and finally through K36.

8.28.2 Digital Inputs

These inputs are supplied by the PLC outputs. When energised the following relays give a specific signal to the drive

- K54: puts the drive into run mode (if there is no speed selected the drive will hold at 0 RPM)
- K57: When not energised the drive will run in reverse, energising the relay will change direction
- K55: Selects 500 RPM speed
- K56: Selects 1500 RPM speed

These inputs are also activated when the keyswitch recovery is used, inputs 1 & 3 are energised through K43 to start the drive running at 500 RPM in reverse.

8.28.3 Relay Outputs

The relay outputs send signals back to the main system & PLC.

- RO3/1 Drive Fault (indicates that the drive has detected a fault. This error is returned to the PLC.
- RO2/3 Drive Running (used by the PLC to confirm a movement command has been processed)
- RO1/3 Drive Enable (activates K64 – used to report that the drive is ready for operation)

8.28.4 Resistor Bank

When the balloon is ascending the motor does not need to generate power as the balloon is trying to pull the cable out. In fact, the opposite is true as, in fact, the energy of the balloon needs to be dissipated. To do this the motor is used to generate electricity, and this energy is dissipated as heat through the brake resistors on the top of the cabinet. These resistors are designed to become hot during use, and are protected by a temperature sensor.

NOTE: This part of the system operates at around 600v DC. No part of the invertor should be touched whilst power is on, or within 10 minutes of isolating the system.

8.28.5 Thermistor Relay

The Thermistor checks the temperature of the main motor. If the motor overheats the drive will stop the system until the motor has cooled down. This motor has been designed to run continuously at very high ambient temperatures. If overheating occurs this could indicate problems with the drive, motor or winch systems.

8.29 PLC (Programmable Logic Control)

The PLC is an industrial computer used to control the balloon during normal operation. The PLC consists of the main microprocessor, input slots which detect signals from relays and other devices, and output slots which send electrical signals to devices within the system.

9 ELECTRICAL FAULT FINDING

Electrical fault finding can be aided by reference to the *Electric Circuit Diagram* pack.

The PLC control system is equipped with a panel display unit, which normally displays ride height, speed and other related settings. In the event of a system fault the mode of this screen can be changed to display alarms, which will aid in the locating of system faults.

There is an alarm screen, which can be accessed by pressing the alarm list function key. If a sensor is tripped or a device not functioning correctly, it will be listed.

Below is a brief overview of system alarms and possible failures.

9.1 Main Safety Relay Trip

This alarm refers to the main 'E-stop' Pilz unit. Normally this alarm would be displayed because another alarm has been triggered. Apart from the emergency recovery keyswitch, no systems will operate until the system has been reset by clearing the alarm and resetting the system on either the reset button on the ground control or main panel.

9.2 Generator CB Trip Q30

This alarm indicates if the breaker for the generator has been tripped. If this breaker should trip during an emergency recovery it should be reset no more than twice and the recovery reattempted. If the breaker continues to trip the auxiliary motor and associated wiring to the panel, and also the wiring from the generator to the panel should be checked by an electrician.

9.3 Mains supply CB Trip Q31

This alarm indicates if the breaker for the main incoming power has been tripped. This breaker is rated considerably larger than the maximum current required and if it should trip the balloon should be recovered on the generator and LTL contacted for advice. Due to the possibility of damaged wiring or components, no attempt should be made to reconnect the power.

9.4 Brake Hydraulic Trip Q33

This alarm indicates if the breaker for the hydraulic brakes has been tripped. If this breaker trips it should be reset no more than twice and the ride should be reattempted. If the breaker continues to trip the brakes will have to be removed using the emergency hand pump and the balloon recovered on the auxiliary motor. An electrician should then check the motor and associated wiring to the panel.

9.5 Auxiliary Motor CB Trip Q32

This alarm indicates if the auxiliary motor breaker has tripped. If this breaker trips it should be reset no more than twice and the recovery reattempted. If the breaker continues to trip the motor and associated wiring should be checked by an electrician.

9.6 MD Brake Unit CB Trip Q34

This alarm indicates if the breaker for the brake on the main motor has tripped. If this breaker trips it should be reset no more than twice. If the breaker continues to trip the brake can be released manually [see Section 6.6] and the ride recovered on the emergency recovery keyswitch. (Refer to emergency operation procedures).

Warning:

This item forms part of a safety critical circuit. It is recommended that only persons authorised by LTL conduct maintenance on this item.

9.7 Winch Blower CB Trip Q35

This alarm indicates if the breaker for the motor cooling fan has tripped. If this breaker trips it should be reset no more than twice. If the breaker continues to trip the balloon can be lowered on the emergency recovery keyswitch (the motor will not overheat while being run at slow speed). As the system checks the operation of this device before allowing the balloon to ascend, it will not be possible to continue operation until the fault has been rectified.

9.8 Winch Drive Fault

There are two reasons why this alarm may be displayed:

1. The power has been removed from the drive. This is usually because the safety relay has been activated, but may also be caused by Q36 tripping or F5 blowing.
2. A fault on the main drive. This can be ascertained from the alarm screen if there are no other alarms listed, except 'winch drive fault'. The balloon should be recovered using the auxiliary motor and not used again until LTL have been contacted.

9.9 Pilz Overspeed Trip

This alarm indicates that the system has exceeded its maximum speed. This alarm would normally indicate a serious fault and the balloon should be recovered using the auxiliary motor (not the emergency recovery keyswitch) and not used again until LTL has been contacted.

Warning:

This item forms part of a safety critical circuit. It is recommended that only persons authorised by LTL conduct maintenance on this item.

9.10 Resistor Overheat

This alarm indicates if the resistor cabinet mounted on top of the main control system has overheated. If the resistors should overheat the ride can be recovered using the auxiliary recovery key.

Warning:

The resistor banks operate at approximately 600 VDC. It is recommended that only qualified electricians remove the covers. Refer to ACS 800 documentation for further details.

9.11 Main Panel 'E-stop'

This alarm indicates if the 'E-stop' on the drive panel is activated. To reset twist the button until it comes out and then reset the system.

9.12 Remote Station 'E-stop'

This alarm indicates if the 'E-stop' on the ground control station (mounted on the decking) is activated. To reset twist the button until it comes out and then reset the system.

9.13 Main winch 'E-stop'

This alarm indicates if the 'E-stop' on the main winch junction box is activated. To reset, twist the button until it comes out and then reset the system.

9.14 Disc Overtravel (1 or 2)

This alarm indicates that one or both of the disc overtravel switches on the top of the gimbal sheave have been tripped. If the balloon has been low-moored it is quite common for these sensors to trip as the rope becomes slack. If these sensors are tripped during normal operation this would indicate a malfunction of two other sensors so the ride should be stopped and LTL contacted.

9.15 Rope Overtravel

This alarm indicates if the rope overtravel switch has been activated. There are two possible reasons why the switch could be activated. First, because the operator has not brought the disc down to the photo-eye after each ride, resulting in a cumulative error after several rides. Or, secondly, there could be a system fault in the way in which the PLC calculates the ride height. Recover the ride using the emergency keyswitch and ensure the disc comes right down to the photo-eye. Reset the system and ensure the ride height counters 1 & 2 are reading zero. If they do not reset, contact LTL. If they do reset, attempt another ride with no passengers, check the height display as the ride ascends and, if everything is normal, allow the ride to ascend to full height and check to see if the rope overtravel is actuated. If everything functions normally, try 4 rides whilst monitoring closely. If all appears normal, record the event and continue the ride. If the ride continues to trip the sensor, or abnormalities are noted as the winch pays out, recover the balloon and contact LTL.

9.16 Fleeting Sheave In

This alarm indicates if the fleeting sheave 'over pay-in' switch has been actuated. Over many flights the position of the sheave can 'drift' a little, as long as the routine maintenance programme is followed the sheave's positioning should be corrected before it gets close enough to trip the switch. If the switch should be tripped it will be necessary to low moor the balloon so the load is taken off the main cable,

and then manually wind the fleeting sheave off the switch until there is a 5mm gap between the switch and the side of the sheave.

If this switch should trip, attention should also be paid to the path of the rope ensuring that no contact has been made with the frame. If there has been contact, the rope should be checked for damage.

9.17 Fleeting sheave pay-out switch tripped

Under normal operating conditions the pay-out switch should not be activated as the rope overtravel switch should be tripped first. Lower the ride with the emergency recovery keyswitch and check the position of the sheave pulley relative to the 'pay-in' switch [see Fig. 5]. Adjust the pulley setting as described in **Section 10.7.5**.

9.18 Height count error

This alarm indicates if there is an error with the method the winch uses to calculate the height of the balloon. The alarm activates if there is a difference of 4m between height count 1 & 2.

9.19 Low Oil Level

This alarm indicates that the hydraulic brake oil level switch has been activated. Check for leaks and top-up to correct level.

9.20 Coupling Guard Open

This alarm indicates that the cover for the auxiliary motor coupling has not been closed properly.

9.21 Thermistor Trip

This alarm indicates if the drive Thermistor (motor overtemp detector) is tripped. If the motor trips on overheat, the ride should be recovered using the auxiliary motor and not the emergency recover keyswitch. The motor should never reach its overtemp state, as the inverter should trip the system on over torque before the motor overheats. If this alarm occurs during normal operation, recover the balloon on the auxiliary motor and contact LTL.

10 INSPECTION & MAINTENANCE

10.1 General Care

The winch is bolted down to the concrete base with 16 anchor bolts M.24. The nuts should be checked for tightness to a torque of 580 Nm (430 ft/lb) once a month.

Paint damage should be touched up to prevent corrosion. Paint to spec RAL1021.

Unpainted metal surfaces can be wiped down with an oily rag to prevent corrosion.

Correct lubrication is essential for the safe operation and long service life of the winch **[see Section 11]**.

Note: The disc brake flange surface must NOT be treated or contaminated with a lubricant or other substance.

The cable is wrapped over the top of the drum surface. It is important that the rope surface is not damaged or contaminated with dirt or grit from overhead work or dirty shoes. The drum surface should be covered for protection if overhead work is proceeding.

Care should be taken not to leave tools or equipment in the winch room where they could become entangled in the moving machinery or cable.

Do not stand or step on vulnerable components such as, hydraulic power pack, fleeter shaft, fleeter limit switches, encoder, electric ducting or motor cowl.

Ensure that equipment like Fire Extinguisher, grease gun, torch and tools are installed and safely stowed.

Generator, fuel, grease and paint must not be stowed in the winch housing.

Before operating the winch ensure all personnel are clear of the cable and moving parts.

Laminate and display 'Lindstrand Winch Emergency Recovery Procedures' in winch housing **[see Display Sheets 1 & 2 in Appendix 7]**.

Display emergency contact numbers for:

- Manager
- Crew Members
- Emergency Services (Fire, Police, Ambulance)
- Airport
- Generator Service Agent
- Electricity Suppliers
- Lindstrand Technologies Ltd
- Lindstrand Technologies Ltd out of hours

10.2 Preventative Maintenance

To give reliable and safe service the winch must be inspected and maintained at regular intervals.

10.3 Daily Inspection

The winch must be inspected daily as detailed in the 'Daily Winch Inspection Report Form' [see LTL-TA3. in Appendix 1]. The form must be completed, dated and signed by the operator and the supervisor. The completed form must be filed and safely stored for future reference [see Section 10.7].

10.4 Weekly Maintenance

The winch must be routinely maintained once a week in addition to the daily inspection. The 'Weekly Maintenance Form' [see LTL-TA4. in Appendix 2] must be completed, dated and signed by the operator and supervisor. The completed form must be filed and stored for future reference [see Section 10.8].

10.5 Annual Survey

The winch must be serviced annually by Lindstrand Technologies Ltd. Engineers. The Annual Inspection Form [see LTL-TA5 in Appendix 3] is for your reference only.

On completion of the survey and corrective work required, an Airworthiness Certificate will be issued.

The cable must also be inspected annually by an independent and certified Cable Inspector. If the cable passes inspection a certificate will be issued.

The winch may not be operated without current certificates.

10.5.1 3-yearly Service

The winch must also undergo a 3-year service. The 3-Yearly Inspection Form [see LTL-TA6 in Appendix 4] is for your reference only, as this service must only be carried out by Lindstrand Technologies Ltd. Engineers.

10.5.2 5-yearly Service

The winch must also undergo a 5-year service. The 5-Yearly Inspection Form [see LTL-TA7 in Appendix 5] is for your reference only, as this service must only be carried out by Lindstrand Technologies Ltd. Engineers.

10.6 Defects

The operating crew are required to be continually aware of the requirements for safe operation of both the winch and balloon and keep equipment under continual observation for defects. Any unusual appearance or noises from the equipment should be reported and investigated.

Any defects suspected or identified must be reported to the supervisor, investigated and cleared or rectified before the winch is operated again.

Defects, rectification and approval must be recorded on the 'Defect Report Form' [see LTL-TA8. in Appendix 6]. The form must be dated and signed by the operator and supervisor. The completed form must be filed and stored for future reference.

Any defects that cannot be simply rectified, or could lead to failure of any component, or endanger the safe operation of the winch must be reported to Lindstrand Technologies Ltd.

The winch and balloon should not be operated until the defect is rectified and approved by LTL.

If in doubt, do not operate. Seek advice from LTL.

10.7 Daily Inspection Schedule

10.7.1 Tether Cable

The nominal cable diameter is 22mm. Check for deformation, crushing and loose or broken wire strands.

The cable between the termination, gimbal and fleeter is particularly vulnerable to distortion.

Check the cable wraps on the drum are bedded correctly in the grooves and are not covered in grit or dirt. Brush with a stiff brush to remove dirt.

Do not grease the cable. It is internally lubricated and exterior grease will only attract dirt.

If the cable is damaged, distorted or frayed it must be inspected by a certified 'Cable Inspector' before the balloon is operated.

After a considerable period of use the cable lubrication may break down, leaving a dry surface and possibly evidence of red rust dirt. In this case, the cable should be renewed.

10.7.2 Cable Termination

See Fig. 2.

Check:

- Cable entry into socket is not distorted
- Loadcell and swivel pins are secure and split pins in place
- Swivel rotates freely
- Loadcell electric cable is free and intact

10.7.3 Winch Structures

Check that there is no damage, loose fasteners or components.

10.7.4 Hydraulic Brake system

Check:

- Check disc brake surface is clean and not contaminated with oil
- Check brake is applied (pads cannot be moved)
- Check for leaks from Power Pack hoses
- Check Power Pack oil level (low level alarm on Visual Display Screen) and top-up if required **[see Fig. 3]**
- For hydraulic oil specification **see Section 11.4.6**

10.7.5 Disengage Brake Systems/Static Dynamic Testing

CAUTION: BRAKES SHOULD ONLY BE REMOVED INDIVIDUALLY WITH MOORING LINES STILL ATTACHED

THIS OPERATION SHOULD ONLY BE PERFORMED BY A COMPETENT PERSON TRAINED TO LTL LEVEL 2 STANDARD

- The hydraulic brake and motor brakes can be controlled from the winch control box display
- From Main Screen [see Fig. A], press 'ENG SCRIN'
- Press 'LOG IN' and enter code [see Fig. F]
- Press 'ENG 1' to enter Engineering Screen Brake Control Screen [see Fig. G]
- From this screen the hydraulic winch brake and motor brake can be controlled using the 'ON' and 'OFF' buttons
- When process complete, return to Main Screen and press 'LOG OUT'

DO NOT REMOVED THE SECOND BRAKE UNTIL IT IS CONFIRMED THAT THE OTHER BRAKE IS APPLIED

10.7.6 Fleeting Sheave

The fleeting sheave and limit switch positions are shown in **Fig. 5**.

With the balloon moored before operations, check the location of the fleeter pulley wheel on the shaft.

The pulley position can wander out of adjustment when the cable is slack and must be reset to the nominal 12mm between pulley side face and 'pay-in limit switch'.

The clearance can be correctly adjusted by rotating the pulley on the threaded shaft when the cable is slack before operations.

Check that the working length of the pulley shaft is well greased and not contaminated with dirt [see **Section 11.4.2**].

10.7.7 Gimbal Sheave

Check cable entry and exit rollers for wear. If the depth of wear groove exceeds 3mm, the rollers must be changed for new ones.

Rock the gimbal sheave housing in both planes to check for smooth, free movement.

10.7.8 Auxiliary Generator

Check fuel, oil and water levels with engine cold.

Check reserve fuel container topped up (not in winch housing).

Start generator and run for 10 minutes.

10.7.9 Winch Housing

Check no standing water or accumulated dust.

Check fire extinguisher present and not discharged.

Check no loose articles in housing.

Check all personnel clear of moving parts before cable operation.

10.7.10 Electrical Systems

All cables should be visually checked for damage (especially where they enter boxes and switches), and should also be securely fixed in place. The gimbal sheave cable, however, should have enough slack to allow for movement.

With cabinet doors open, check that all circuit breakers are in the on position. If any of the mooring winch circuit breakers have tripped the system will not reset.

The PLC situated in the centre compartment of the control box has four status lights. The light marked 'BATT.V' should not be illuminated. If it is, it means the internal battery needs to be changed immediately or the program will be lost.

If the winch has air conditioning unit or heaters fitted, check their operational status as it is not monitored by the PLC.

Each limit switch and 'E-stop' must be activated manually and checked via the Alarm Screen **[see Fig. B]**. Acknowledge each alarm before testing the next one.

10.8 Weekly Maintenance Schedule

The same day each week should be allocated to the weekly checks and actions which must be carried out in addition to the daily inspection routine.

10.8.1 Gearbox Oil

Check the Main Motor, Main Drive and Auxiliary Drive gearbox oil levels before operations when the oil has settled overnight.

If a significant drop in level is observed, check for leaks.

If no leaks are evident or cannot be sealed, inform LTL service engineers **[see Sections 11.1 and 11.2]**.

10.8.2 Gimbal Sheave

Clean and grease the gimbal sheave **[see Section 11.4.1]**.

10.8.3 Fleeting Sheave

Clean the fleeting shaft and grease the fleeting sheave **[see Section 11.4.2]**.

10.8.4 Auxiliary Gear Drive

Grease the gear pinion and wheel **[see Section 11.4.5]**.

10.8.5 Cable Swivel

Grease the cable swivel **[see Section 11.4.7]**.

10.8.6 Bilge Pump

Clean out the bilge pump well. Fill well with water and test pump action.

10.8.7 Emergency Recovery Procedures

Emergency recovery procedures should be conducted both to check the equipment and familiarise the operators.

After the preceding daily inspection and weekly maintenance schedule have been completed, the balloon should be unmoored and raised to 20 metres.

The following emergency recovery procedures should be conducted, with reference to:

- 'Lindstrand Winch Emergency Recovery Procedures' **[see Display Sheets 1 & 2 in Appendix 7]**.
- Keyswitch recovery **[see Section 6.8]**
- Auxiliary Motor on Mains Recovery **[see Section 6.9]**
- Auxiliary Motor on Generator Recovery **[see Section 6.2]**

11 WINCH LUBRICATION

The winch has moving parts that are dependent upon lubrication for safe operation and service life.

11.1 Winch Gearboxes

The winch is driven through 3 oil-filled gearboxes.

The main motor drives the drum shaft through an integral primary stage and a separate final drive gearbox.

The auxiliary motor drives the drum flange gear through an integral gearbox.

All 3 gearboxes have oil level sight glasses, and the level should be checked at least once a week with the winch stopped and the oil settled.

If the oil level drops check for leaks at plugs and seals and top-up level.

Oil in all three gearboxes should be changed after 10,000 hours or 3 years service.

11.2 Mooring Winch gearboxes

There are 20 mooring winches supplied with each winch. The mooring winches have integral gearboxes.

The gearboxes should be filled to the lower oil plug level on the side of the gearbox.

Check for leaks at the plugs and shaft seal.

Oil should be changed after 10,000 hours or 3 years service.

11.3 Oil Specification

Do not mix mineral and synthetic oil. The oil specification for each gearbox is as follows:

- **Main motor gearbox:** SEW. Type RF 107
Mineral Oil ISO – VG.220
Quantity: 6.0 litres

- **Auxiliary motor gearbox:** SEW. Type R 107
Mineral Oil ISO – VG.220
Quantity: 6.3 litres

- **Main drive gearbox:** SEW. Type MC 309
Mineral Oil ISO – VG 460 EP
Quantity 6.5 litres

- **Mooring winch gearbox:** SEW. Type D190
Mineral Oil ISO – VG.220
Quantity: 2.3 litres

11.4 Greasing Points

The winch mechanism is lubricated by grease nipples distributed about the winch. There is a wide disparity in the quantity of grease to be applied to the grease nipples. Do not overfill or starve the grease points but observe the following guide.

Grease Specification: DIN 51825 code KPF2K-2 (SKF.LGEM2), or equivalent Lithium/Molybdenum based grease, to be used at all grease points as follows:

11.4.1 Gimbal Sheave

There are 5 grease points on the gimbal sheave: one in the centre of the sheave cross shaft, one each side of the hub, and one above each of the main shaft bearings.

The points should be sparingly greased with one pump of the grease gun each week. If excessive grease is exuded around the shaft, reduce the application.

11.4.2 Fleeting Sheave

There are 2 grease points on the hub of the fleeter pulley wheel. The points should be greased daily until grease is visibly exuded around the shaft.

The excess grease should be smeared along the shaft thread.

Once a week clean the shaft thread and apply a coat of new grease.

Keep the floor under the fleeting sheave clean.

11.4.3 Drum shaft bearings

The drum shaft bearings are packed with SKF LGEM 2 Grease on assembly. If required, the grease should only be inspected or repacked by LTL personnel at service intervals.

11.4.4 Final Drive Gearbox

The gear box has 3 grease points. The grease points lubricate the shaft seals and prevent dirt ingress.

The points should be lubricated with a maximum of 30g of grease at 12-month intervals by the Lindstrand Technologies service engineer.

11.4.5 Auxiliary motor gear drive

Ensure the main winch system drive is 'off' before lubricating the gear drive.

Open the auxiliary pinion gear cover for access to pinion and ring gear.

Rotate the pinion gear with the auxiliary motor hand wheel until the grease nipple is accessible. Grease sparingly until pinion slides freely on shaft, once a month.

Apply grease by brush to the pinion gear teeth and the ring gear teeth once a month, until there is no evidence of bare metal on the teeth faces.

11.4.6 Brake Hydraulic Power Unit

Prior to the first test flight, (when the balloon has been un-moored and all the load is through the main cable), test the ‘holding power’ of the main hydraulic brake by disengaging the motor brake by manually pulling the lever on the back of the main motor. There may be a small amount of gearbox backlash, however, the main drum should not be able to rotate any more than 100mm.

Check the braking force of the motor brake. Configure the balloon in the high moored position with the mooring lines attached but without any tension so that the full load is on the main cable. Release the spring applied hydraulic brake using the hand pump and check that the motor brake holds the full load of the balloon.

The Hydraulic Power Unit operates the drum disc brake **[see Fig. 3]**.

- Check for hydraulic oil leaks
- If ‘Low Oil Level’ indicates on Visual Display Screen top-up tank
- Replace hydraulic oil at 24-month intervals
- Only use Hydraulic Oil specification ISO.32
- Quantity: 1.8 litres

11.4.7 Cable Swivel

A right angle grease nipple is located under the barrel of the swivel.

This should be lubricated sparingly at weekly intervals and any excess grease expelled should be cleaned off.

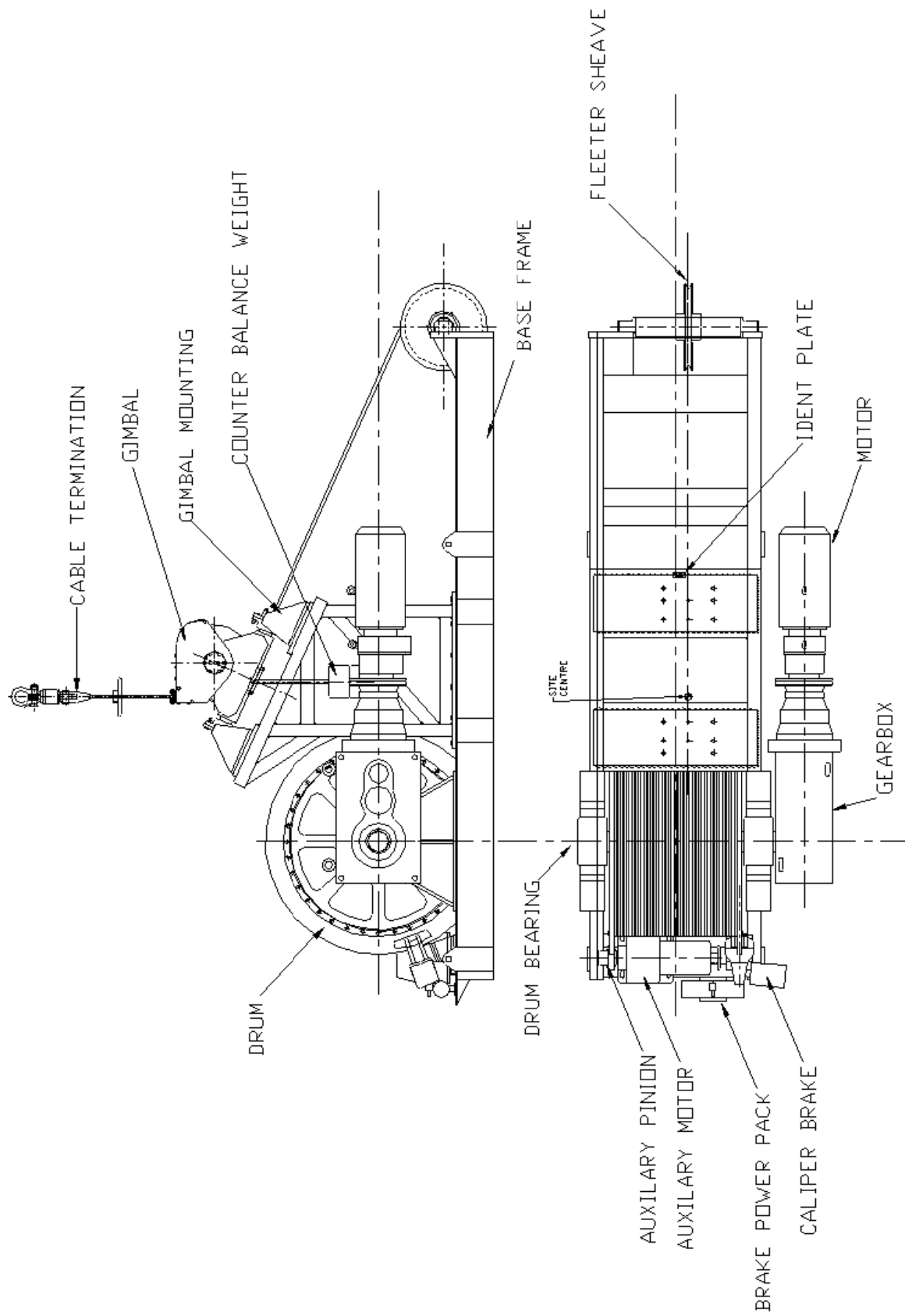

Figure 1: Winch System Layout

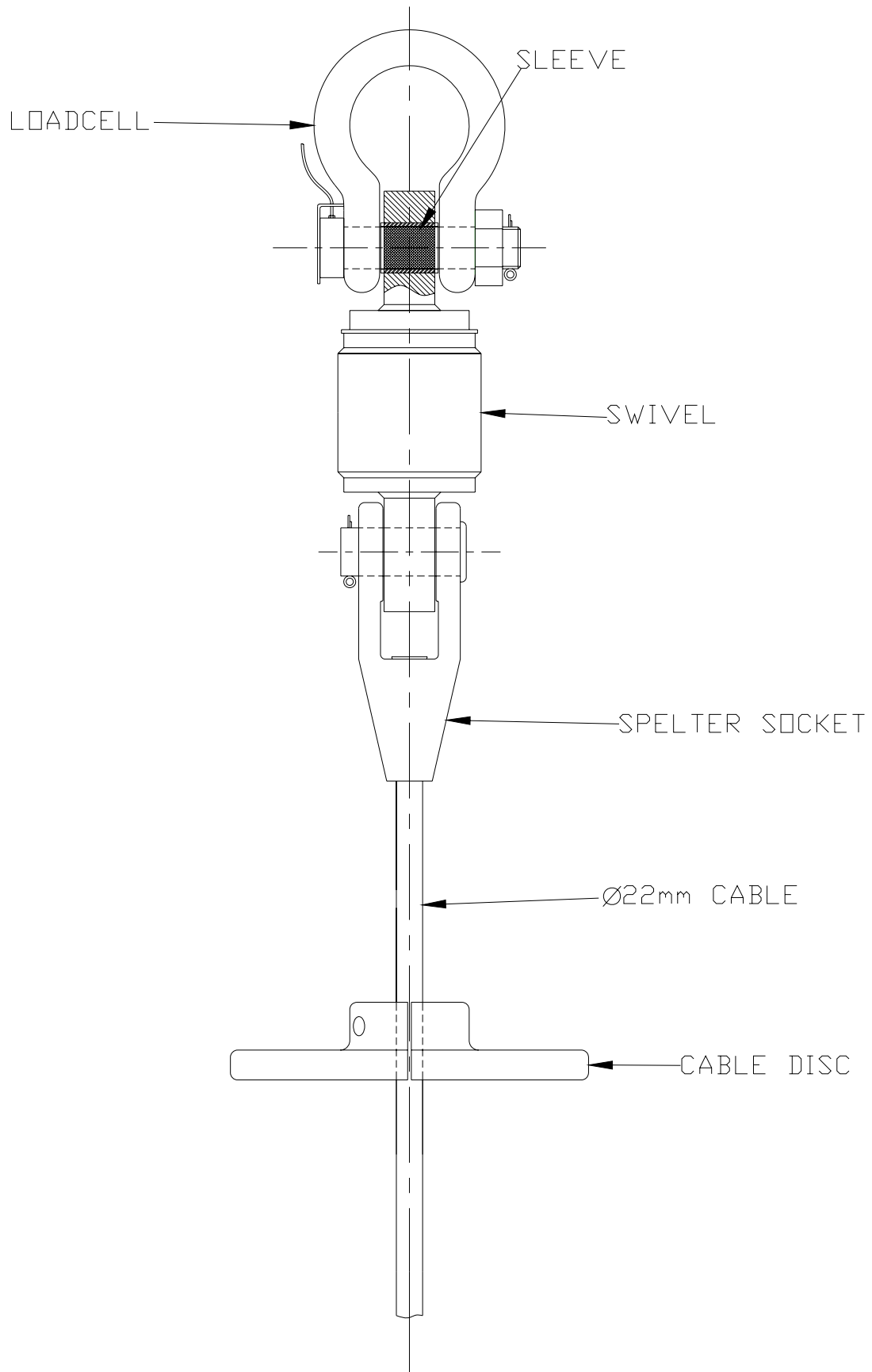

Figure 2: Cable Termination

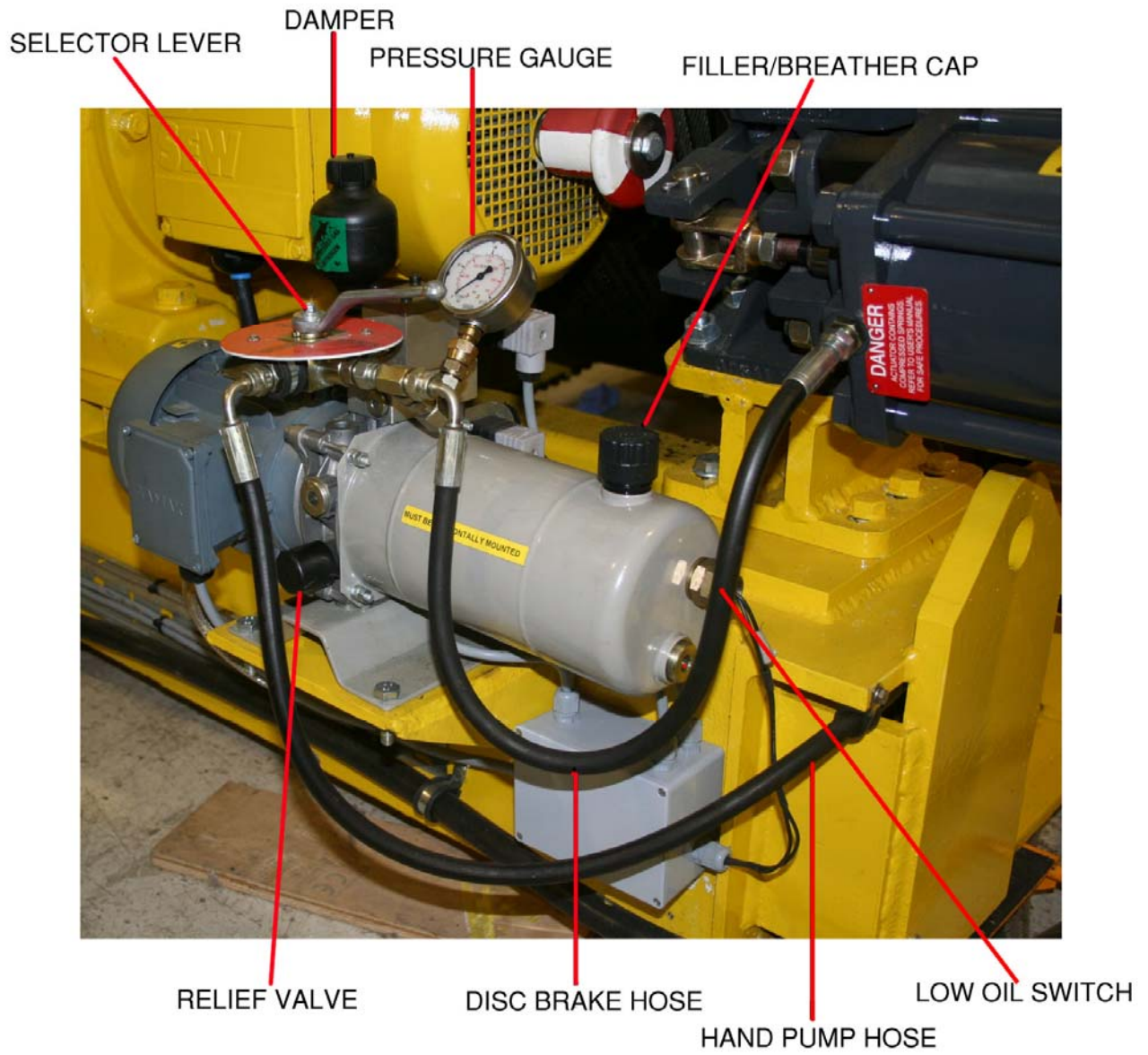
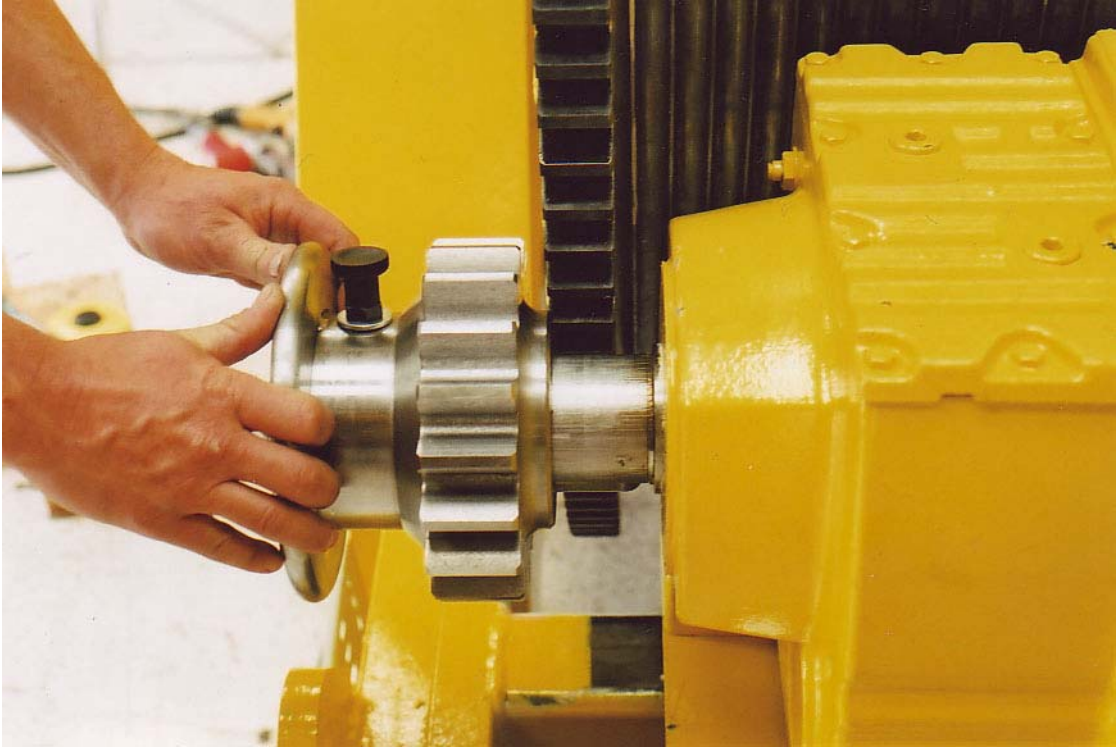

Figure 3: Disc Brake Power Unit



Pinion Disengaged



Pinion Engaged

Figure 4: Auxiliary Drive Pinion Engagement

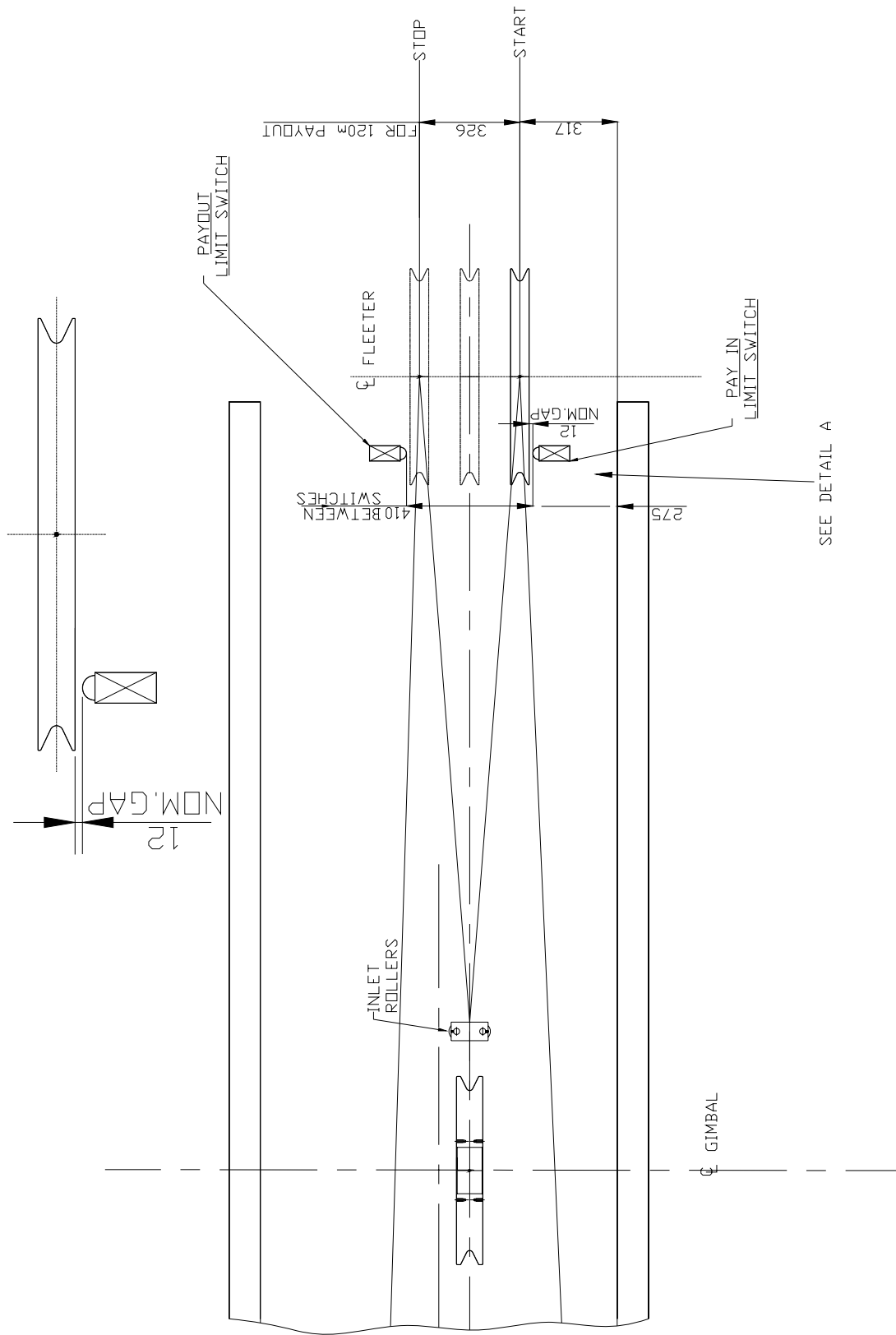

LINDSTRAND WINCH FLEETER LIMIT STOPS

Figure 5: Fleeter Limit Stop

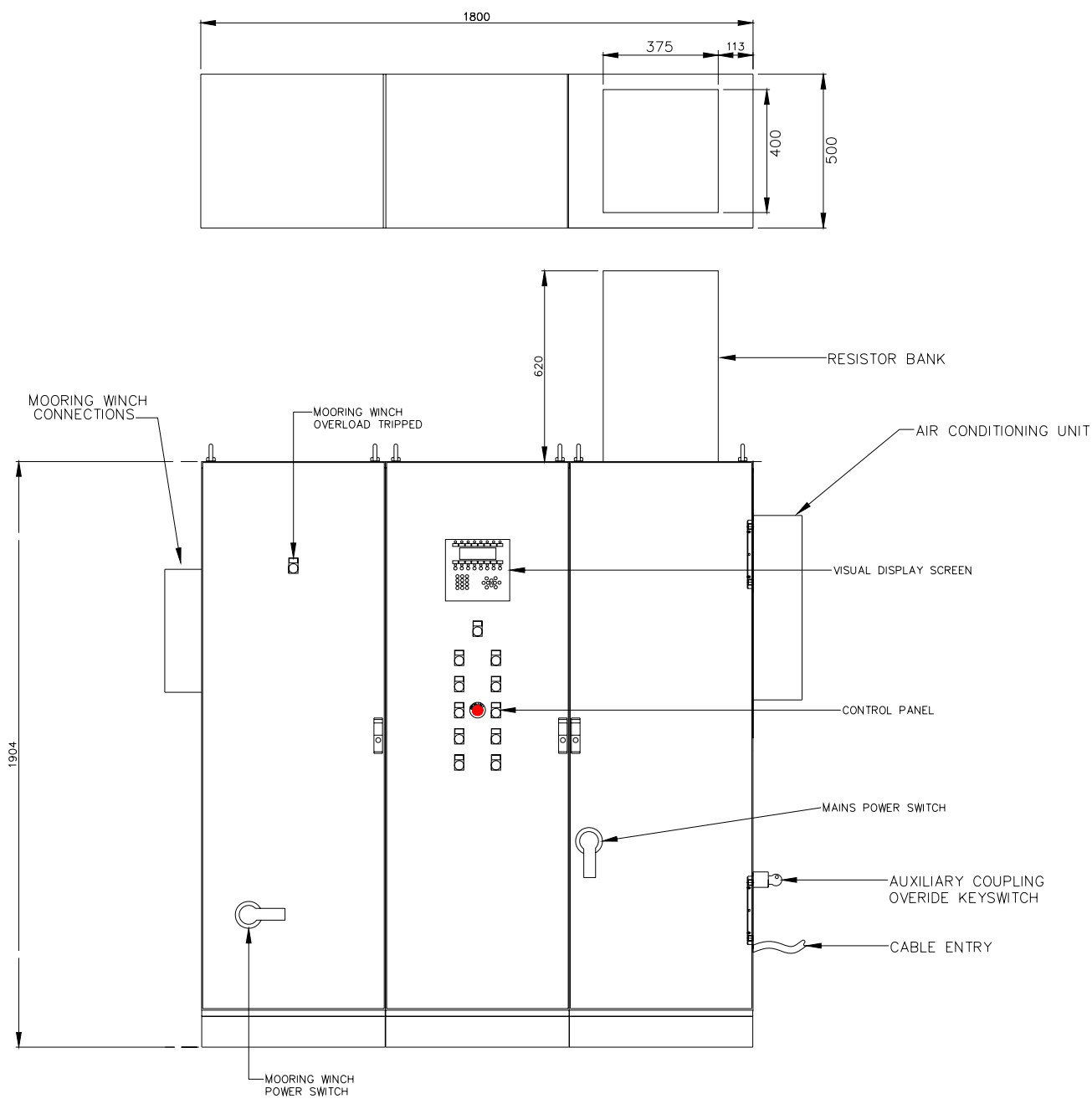

Figure 6: Control Cabinet



Figure 7: Winch Control Panel



Figure 8: Ground Control Panel

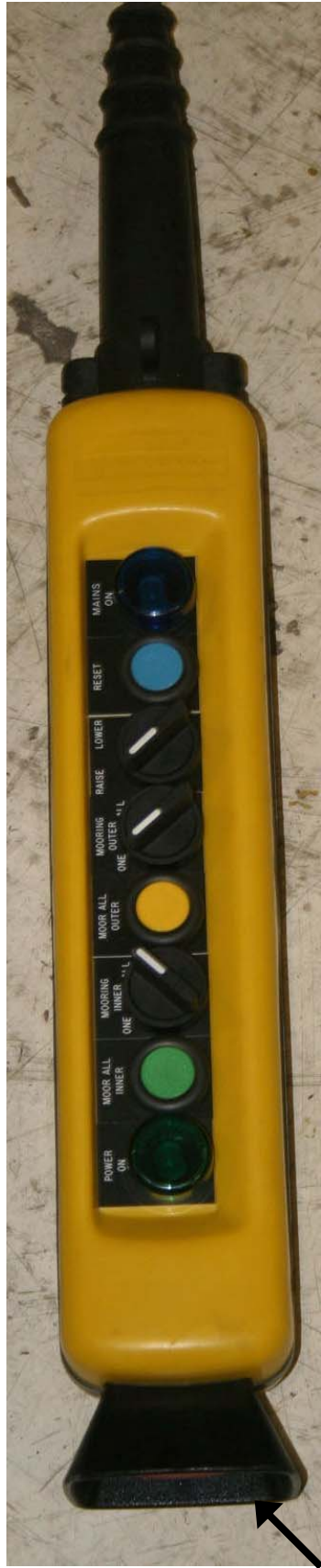

Mooring Winch Emergency Stop

Figure 9: Mooring Pendant Control

LTL – TA3	Lindstrand Winch DAILY INSPECTION FORM	DATE:
-----------	---	-------

NB. When performing daily inspections of the winch system, care should be taken when moving around the container/pit to ensure that sensors on ancillary devices do not get damaged. In particular, avoid stepping on the main motor cowling.

	PASS/FAIL	DEFECT NO.
Cable and Connections		
<ul style="list-style-type: none"> ▪ Carry out a full cable inspection including cable termination socket as specified in Section 10.7.1 of WOMM. ▪ Check that swivel and load-cell connections are tight and secure & there is no evidence of damage or wear. 		
Winch Structure		
<ul style="list-style-type: none"> ▪ No cracks, distortion, loose components or damage 		
Hydraulic Brake System		
<ul style="list-style-type: none"> ▪ Check disc brake flange is clean ▪ Check brake hoses & hydraulic power pack for signs of leakage ▪ Before turning main power on, check hydraulic brakes are applied. Note that if brakes are not applied, then brake pads can be moved slightly 		
Static Dynamic Testing		
<ul style="list-style-type: none"> ▪ Check operation of hydraulic brakes ▪ Check operation of motor brake ▪ With full load of balloon on cable with mooring lines attached: <ul style="list-style-type: none"> - Manually energise hydraulic brakes & check motor brake holds system. Re-apply brake. - Manually energise motor brakes & check hydraulic brake holds the system. Re-apply brake. 		
Fleeting Sheave		
<ul style="list-style-type: none"> ▪ Inspect the cable groove on fleeting sheave for any damage or deep grooving. There should be no grooving deeper than 3mm. ▪ Check start position of fleeting sheave with balloon moored. The side of the pulley should have a gap of approx. 12mm from the pay-in limit switch [see Fig. 5]. ▪ Check that threaded section of fleeter shaft is suitably greased & not contaminated 		

<ul style="list-style-type: none"> Check the fleeting sheave pulley by pushing pulley from side-to-side on shaft. Sideplay should not exceed 1mm. 		
Gimbal Sheave		
<ul style="list-style-type: none"> Check free & smooth movement of sheave by moving from side to side and moving the cover fore & aft 		
<ul style="list-style-type: none"> Check cable entry & exit rollers for signs of damage or wear. There should be no damage or grooving deeper than 3mm (0.125") 		
Generator back-up		
<ul style="list-style-type: none"> Check fuel level, oil level & battery charge 		
<ul style="list-style-type: none"> Check coolant level with cold engine 		
<ul style="list-style-type: none"> Check generator is functioning by starting & running for 10 minutes 		
<ul style="list-style-type: none"> Check reserve fuel on site 		
Winch Housing		
<ul style="list-style-type: none"> Check that there is no dirt or accumulated water 		
<ul style="list-style-type: none"> Fire extinguisher – check not discharged 		
<ul style="list-style-type: none"> Check that no loose articles within winch housing 		
Electrical Systems		
<ul style="list-style-type: none"> Check electrical cables for damage 		
<ul style="list-style-type: none"> Check inside winch control box that no circuit breakers have tripped. Some circuit breakers are not monitored by PLC & can only be checked visually. 		
<ul style="list-style-type: none"> Check on PLC that battery status light is not lit. 		
<ul style="list-style-type: none"> If fitted, check that air conditioner/heater is operational. 		
<ul style="list-style-type: none"> Check operation of all limit switches and E-stops: rope over-travel switch, disc over-travel switches, fleeting sheave over pay-out & over pay-in switches, 'E-stop' on winch control box, 'E-stop' on winch & 'E-stop' on ground box. These switches can be activated by hand and their operation checked from the PLC screen. 		

Inspection carried out by:

Passed by (supervisor):

APPENDIX 2

LTL – TA4	Lindstrand Winch WEEKLY INSPECTION FORM	DATE:
-----------	--	-------

In addition to the items on the Daily Inspection Form, please carry out the following checks each week:

Refer to section 10.8 of WOMM & Appendix 7 below	<u>PASS/FAIL</u>	DEFECT NO.
▪ Check oil levels in main motor gearbox, drive gearbox & auxiliary motor gearbox		
▪ Clean and grease gimbal sheave		
▪ Clean and grease fleeting sheave		
▪ Grease auxiliary drive pinion and gear		
▪ Clean and grease cable swivel		
▪ Clean bilge pump well and strainer, and check operation		
▪ Elevate balloon and conduct 'Emergency Recovery procedures:		
- Keyswitch recovery		
- Auxiliary motor recovery on mains power		
- Auxiliary motor recovery on generator power		

Inspection carried out by:

Passed by (supervisor):

LTL – TA5	Lindstrand Winch ANNUAL INSPECTION FORM	DATE:
-----------	--	-------

NB: This form is for reference only: LTL engineers must carry out the Annual Winch Inspection.

	PASS/FAIL	DEFECT NO.
Winch		
▪ Check overall condition of winch for corrosion and wear		
▪ Check swivel and load shackle for wear		
▪ Check main motor drive coupling		
▪ Check gearbox backlash		
▪ Purge cell assemblies with grease		
▪ Check/clean brake flanges		
▪ Check brake pads for wear/contamination. Adjust air gap		
▪ Change hydraulic oil and check hoses and seals for leaks		
▪ Check main winch drum bearings		
▪ Grease drum shaft		
▪ Grease final drive gearbox		
▪ Check wear of fleating sheave		
▪ Clean fleating sheave and purge with grease		
▪ Check/replace entry rollers		
▪ Check gimbal sheave bearings and purge with grease		
▪ Check/replace exit rollers		
▪ Check auxiliary gearbox coupling clean/grease		
▪ Check position and connection of all limit switches and count proxies		
▪ Check limit switches for water ingress		
▪ Check all electrical terminals		
▪ Check main motor brake pads for wear and contamination		
▪ Check adjust/main motor brake air gap		
▪ Check aluminium disk is secure and at correct height		
▪ Check all main winch bolts are secure		
▪ Check main drum rope clamps are secure		
▪ If fitted, clean/replace filters on resistor box		

Static dynamic testing		
▪ Check operation of hydraulic brakes		
▪ Check operation of motor brake		
▪ With full load of balloon on cable with mooring lines still attached:		
- Manually energise hydraulic brakes & check motor brake holds the system. Reapply brakes.		
- Manually energise motor brake & check hydraulic brake holds the system. Reapply brake.		
▪ With inverter on-line at zero speed and brakes removed, ensure inverter power does not exceed 120%		
Flight Tests		
▪ Check operation of winch using ground control box		
▪ Check operation of winch using gondola remote control		
▪ Elevate balloon to 15 metres & recover using keyswitch recovery		
▪ Elevate balloon to 15 metres & recover using auxiliary motor on mains		
▪ Elevate balloon to 15 metres & recover using auxiliary motor on generator		
Mooring system tests		
▪ Check oil level and replenish as necessary		
▪ Check air gap on brakes		
▪ Check mooring winch pendant for operation & water ingress		
▪ Check mooring winch drums		
▪ Check operation of each winch		
Servicing		
1. Ensure emergency generator has been serviced & is operational		
2. If fitted, ensure lighting generator has been serviced & is operational		
3. Ensure main winch cable & flying wires have been inspected by a qualified Cable Inspector who can provide the appropriate certification tests & documentation		

Signed, for and on behalf of LTL:

APPENDIX 4

LTL – TA6	Lindstrand Winch 3-YEARLY INSPECTION FORM	DATE:
-----------	--	-------

		PASS/FAIL	DEFECT NO.
Main Winch Gearbox			
	<ul style="list-style-type: none"> ▪ Change oil in all 3 gearboxes after 40,000 rides (or 3 years, whichever is soonest), and check for leaks 		
Mooring Winches			
	<ul style="list-style-type: none"> ▪ Change oil in all 20 mooring winch gearboxes after 10,000 hours (or 3 years, whichever is soonest) 		

Inspection carried out by:

Passed by (supervisor):

LTL – TA7	Lindstrand Winch 5-YEARLY INSPECTION FORM	DATE:
-----------	--	-------

	PASS/FAIL	DEFECT NO.
Hydraulic brake power pack		
<ul style="list-style-type: none"> ▪ Check brake pads for wear and change if necessary. 		
<ul style="list-style-type: none"> ▪ The power pack should be sent to LTL for overhaul or replacement 		
<ul style="list-style-type: none"> ▪ The brake callipers should be sent back to LTL for overhaul 		

Inspection carried out by:

Passed by (supervisor):

**LINDSTRAND WINCH EMERGENCY RECOVERY
PROCEDURES**

DISPLAY SHEET 1

**P.L.C DISABLED – SCREEN DOWN
KEYSWITCH RECOVERY**

1. 'E-STOP' IN
2. OPERATIONS MODE KEYSWITCH TO 'EMERGENCY'
3. ALL 'E-STOPS' OUT
4. PRESS RESET AND WAIT UNTIL INVERTOR COMES ON-LINE
5. EMERGENCY RECOVER KEY TO 'EMERGENCY' HOLD KEY ON UNTIL CABLE DISC DESCENDS TO NORMAL CUT-OUT LEVEL
6. 'E-STOP' IN
7. OPERATIONS MODE KEYSWITCH TO 'NORMAL'
8. WHEN PROBLEM FIXED ZERO RIDE HEIGHT
9. 'E-STOP' OUT
10. PRESS 'RESET'

**MAIN MOTOR DISABLED
AUXILIARY MOTOR ON MAINS RECOVERY**

1. 'E-STOP' IN
2. ENGAGE AUXILIARY GEAR COUPLING
3. CLOSE GEAR COVER
4. OPERATION MODE KEYSWITCH TO 'EMERGENCY'
5. ALL 'E-STOPS' OUT
6. PRESS RESET
7. AUXILIARY COUPLING ENGAGED INDICATOR ON
8. AUXILIARY MOTOR CLEAR TO RUN INDICATOR ON
9. PRESS 'AUXILIARY START'
10. PRESS 'AUXILIARY STOP' WHEN DISC DESCENDS TO NORMAL CUT-OUT LEVEL
11. 'E-STOP' IN
12. DISENGAGE GEAR COUPLING
13. CLOSE GEAR COVER
14. OPERATION MODE KEYSWITCH TO 'NORMAL'
15. WHEN PROBLEM FIXED ZERO RIDE HEIGHT
16. 'E-STOP' OUT
17. PRESS 'RESET'

DISPLAY SHEET 2**MAINS POWER LOST****AUXILIARY MOTOR ON GENERATOR RECOVERY**

1. 'E-STOP' IN
2. ENGAGE AUXILIARY GEAR COUPLING
3. CLOSE GEAR COVER
4. GENERATOR
 - BREAKERS OFF
 - PRIME
 - START
 - BREAKER ON
5. OPERATIONS MODE KEYSWITCH TO 'EMERGENCY'
6. SUPPLY KEYSWITCH TO 'GENERATOR'
7. ALL 'E-STOPS' OUT
8. RESET
9. AUXILIARY COUPLING ENGAGED INDICATOR ON
10. AUXILIARY MOTOR CLEAR TO RUN INDICATOR ON
11. AUXILIARY START
12. AUXILIARY STOP WHEN DISC REACHES NORMAL CUT-OUT LEVEL
13. 'E-STOP' IN
14. GENERATOR – OFF, STOP
15. DISENGAGE GEAR COUPLING
16. CLOSE GEAR COVER
18. OPERATION MODE KEYSWITCH TO 'NORMAL'
17. SUPPLY KEYSWITCH TO 'MAINS'
19. WHEN POWER IS RETURNED ZERO RIDE HEIGHT
18. PRESS 'RESET'

TO RESET RIDE HEIGHT FROM MAIN SCREEN

1. PRESS 'ENG SCR' ON DISPLAY
2. PRESS 'ENC'
3. PRESS 'RESET' ON DISPLAY
4. PRESS 'BACK'